

## ***IK-2000-PRO Series***

*Boiler Feedwater Quality Sensor Module for use with OEM Controllers*





## Related Statements

The manufacturer shall not be liable for direct, indirect, special, incidental or consequential damages resulting from any deficiency or omission in this manual. The manufacturer reserves the right to make changes to this manual and the products described in it at any time without notice or liability. Revised versions can be found on the manufacturer's website.

## Safety Information





Please read this manual completely before unpacking, installing and operating this equipment. In particular, pay attention to all dangers, warnings and precautions, otherwise, it may cause serious personal injury to the operator or damage to the equipment.

## Use of Danger Information

 <b>Danger</b>
Indicates a potentially or urgent dangerous situation that, if not avoided, will cause death or serious injury.
 <b>Warning</b>
Indicates a potentially or very dangerous situation that, if not avoided, may cause serious personal injury or death.
 <b>Warning</b>
Indicates a potentially dangerous situation that may cause a certain degree of personal injury.
<b>Attention</b>
Indicates conditions that if not avoided, will cause damage to the instrument. This is information that needs special emphasis.

## Warning Label

Please read all labels and marks attached to the instrument. Failure to follow the instructions on these safety labels may result in personal injury or damage to the instrument.

	If this symbol appears in the instrument, it means refer to the operation and/or safety information in the instruction manual.
	If there is this mark on the instrument housing or insulator, it means there is a risk of electric shock or death from electric shock.
	Static electricity can damage the delicate internal electronic components, resulting in reduced performance or eventual failure of the instrument.
	Electrical equipment marked with this symbol cannot be disposed of through the European public waste system after August 12, 2005. In order to comply with European regional and national regulations (EU Directive 2002 / 98 / EC), European electrical equipment users must now return abandoned or expired equipment to the manufacturer for disposal without any cost.

## Table of Contents

<b>1. Specifications .....</b>	<b>4</b>
<b>2. Product Description.....</b>	<b>5</b>
<b>3. Features.....</b>	<b>5</b>
<b>4. Description.....</b>	<b>6</b>
<b>5. Pyxis Guardian PRO Hardware &amp; Display Features .....</b>	<b>7</b>
<b>6. Part Numbers &amp; Ordering Details.....</b>	<b>Error! Bookmark not defined.</b>
<b>7. Analyzer Dimension and Mounting.....</b>	<b>10</b>
7.1. Analyzer Dimension .....	10
7.2. Analyzer Installation & Component Pressure/Temperature Ratings.....	15
7.2.1. Analyzer Component Pressure & Temperature Ratings.....	15
7.2.2. Installation Requirements.....	15
7.2.3. Sample Water Connections.....	16
7.3. Flowmeter and Electric Isolation Valve.....	17
7.3.1. Flowmeter Specifications & Wiring.....	17
7.3.2. Electric Sample Isolation Valve Specifications & Wiring.....	18
<b>8. PowerPACK Pro-5 Operation Guide.....</b>	<b>19</b>
8.1. Electrical Connection .....	19
8.2. Corresponding Sensor 4-20mA Output Assignments & Ranges for PowerPACK Output .....	21
8.3. PowerPACK Pro-5 Quick Start-up Procedure.....	23
8.3.1. Keys.....	23
8.3.2. Device Power-up & Sensor Scanning.....	23
8.3.3. Status Bar Symbols.....	24
8.3.4. Hiding the Sensor Reading.....	24
8.3.5. Ethernet Settings.....	24
8.3.6. Device Information.....	11
8.4. Sensor Setup & Calibration Using PowerPACK Pro-5 Local Display .....	11
8.4.1. Sensor Configuration.....	11
8.4.2. Sensor Diagnosis .....	12
8.4.3. Sensor Information.....	12
<b>9. Sensor Calibration with uPyxis.....</b>	<b>13</b>
9.1. Dissolved Oxygen (DO) Calibration – ST-774 .....	14
9.2. Sulfite (SO <sub>3</sub> ) Calibration – ST-765SS-SO <sub>3</sub> .....	18
9.3. pH Calibration – ST-765SS-SO <sub>3</sub> .....	20
9.4. ORP Calibration – ST-765SS-SO <sub>3</sub> .....	22
9.5. Fluorescein (Tracer) Calibration – ST-525SS-T.....	23
9.6. Conductivity (TDS) Calibration – ST-724.....	24
<b>10. Replacing ST-765SS-SO<sub>3</sub> pH, ORP and Sulfite Electrode Head .....</b>	<b>25</b>
<b>11. Replacing ST-774 Dissolved Oxygen Cartridge Assembly (DCC-2) .....</b>	<b>26</b>
<b>12. Sensor Cleaning with Pyxis Probe Cleaning Kit .....</b>	<b>27</b>

## 1. Specifications

Item	IK-2000-PRO	IK-2010-PRO	IK-2020-PRO	IK-2030-PRO	IK-2040-PRO
P/N	45050	48852	41319	45232	47516
Guardian PRO Boiler Feedwater	Level 1	Level 2	Level 3	Level 4	Level 5
Dissolved Oxygen Measure Range	0.1 - 2,000 ppb / ±0.3ppb				*NA*
Dissolved Oxygen Method	Optical - Blue Light Irradiated Excitation / Red Light Reference				*NA*
Temperature Measure Range	0 °C – 50 °C (32 - 122° F) / ± 0.2% of value – Taken from ST-774				*NA*
Sulfite Measure Range	*NA*	0.00 – 100.00 ppm / ± 0.01ppm			*NA*
Sulfite Method	*NA*	Bare Gold – Electrochemical Method			*NA*
pH Range	*NA*	0.01 – 14.00 pH / ± 0.01pH			*NA*
ORP Range	*NA*	-1,500 to 1,500mV / ±1mV			*NA*
Fluorescein Range	*NA*	*NA*	*NA*		*NA*
Fluorescein Method	*NA*	*NA*	*NA*		*NA*
Conductivity Range	*NA*	*NA*	*NA*	0.02 – 1,000	*NA*
Conductivity Method	*NA*	*NA*	*NA*	Hastelloy Dual	*NA*
Conductivity Cell Constant (K)	*NA*	*NA*	*NA*	0.3	*NA*
Measurement Interval	Continuous Measurement w/4 Second Delay				
PowerPACK Pro-5 P/N	MA-PS-5				
Power Input	100-240V AC (50/60Hz) w/3.0 AMP Fuse				
Power Output	24V DC, 30W				
Display	2.4" Color 320 x 240 Resolution				
USB	1 x USB host for sensor firmware updating				
Communication	Up to 10x 4-20mA Outputs from Pyxis sensors, 1xRS-485 Modbus, 1x TCP Modbus				
7-Pin Sensor Connection	Direct to PowerPACK – No Conversion Needed				
8-Pin Sensor Connection	Requires CC-78M Conversion Adapter Cable – <i>Sold Separately See Optional Accessories</i>				
Signal Input Adapter	Up to 10x 4-20mA & RS-485 ( <i>from Pyxis sensor output</i> )				
Signal Output Adapter	Up to 10x 4-20mA & RS-485				
Analog Output Cable (4-20mA)	CS-FNS-2.6P (6-Wire) Flying Lead Cable(s) with 7-Pin Female Adapter Provided				
Digital Output Cable (RTU)	CR-MR-2.6P (2-Wire) Flying Lead Cable with 2-Pin Female Adapter Provided				
Enclosure Material	ABS				
Enclosure Rating	IP54				
Panel Dimension (H x W x D)	Panel 600H x 900W x 370D mm				
Panel Approximate Weight	Panel ~ 25 kg				
Panel Operational Temperature	40 – 120°F (4-49 °C)				
Panel Storage Temperature	Instrument: -4 – 131°F (-20 – 55°C) / Sensors 32 – 122°F (0 – 50°C)				
Panel Wet Material	Hastelloy/304SS/316SS/Glass/Gold/Platinum/CPVC/PTFEPOM/ABS/PEEK/PET/NBR/PC				
Sample Water Temperature <sup>†</sup>	40 – 120°F (4-49°C) <sup>†</sup>				
Sample Water Pressure	7.25 – 30 psi (0.05 – 0.2Mpa) Inlet / Atmospheric Drain Outlet				
Sample Water Flow Rate	100 - 500mL / Minute				
Sample Line Size	¼-inch OD Stainless Steel Tubing with Swagelok Compression Inlet & Outlet				
Rating	IP-65 Panel-Display / IP-67 Sensors				
Regulation	CE / RoHS / UKCA				
Sensor Warranty (All)	13 Months				
ST-765SS-SO3 Electrode Warranty	6 Months				
ST-765SS-SO3 Electrode Service Life	12-24 Months Depending on Water Quality				

Specifications are subject to change without notice. \*NA\* = Sensors not included but may be later purchased & field installed if desired by user. <sup>†</sup> Requires Installation Downstream of Sample Cooler

## 2. Product Description

The Guardian PRO-IK-2000-PRO series are multi-parameter inline water quality sensor panels specifically designed as a 'Turn-Key' monitoring solution capable of using any OEM controller for boiler feedwater and chemical treatment applications ranging from low to high pressure operations. The Guardian PRO boiler feedwater series is offered in "ONE-PANEL" design, with a variety of Pyxis Lab smart sensor options based on the application and need, all powered by the PowerPACK Pro-5 external power supply and communication module. This format allows the user the flexibility to begin with a base model and add sensor capability over time and as desired, without the need to replace or configure anything. Simply plug in the new sensor to the available sensor pigtail on the analyzer, and the PowerPACK Pro-5 module on the Guardian PRO will automatically power, recognize, display, configure and initiate operation, calibration interface and data communication of the added sensor, enabling users to mount and wire any OEM controller to the panel for a customized solution to meet the application needs. With all sensor options installed, the Guardian PRO boiler feedwater series offers highly accurate and repeatable, real-time measurement, display, and data-logging of sample water Dissolved Oxygen (ppb), Temperature (°C/°F), pH, ORP (mV), Sulfite (ppm), Conductivity (µS/cm), Total Dissolved Solids (ppm) and Sample Flow Rate (mL/Min) utilizing proprietary Pyxis Lab smart sensor technology coupled with a Pyxis color touch screen display and data logging terminal.

The Guardian PRO IK-2000-PRO series are equipped with the new PowerPACK Pro-5 and reserves 4 sensor mounts for flexibility in adding sensors. The panel is also uniquely designed with reserved spacing to allow the installation of any OEM controller -or- the Pyxis UC-100A display/data logging terminal based on customer desire. The PowerPACK Pro-5 offers 10x 4-20mA sensor outputs , 1x RS485 and 1x TCP connection to enable communication to any OEM controller, PLC or DCS network. The PowerPACK Pro-5 also comes Bluetooth 5.0 enabled with USB-C port to allow the use of the uPyxis Mobile or Desktop app for sensor diagnostics, configuration and calibration.

The Guardian PRO boiler feedwater series should always be installed downstream of a sample cooler and the sample pressure should not exceed 30psi, ideally taken from the storage vessel of the deaerator or feedwater tank. The analyzers are offered in a convenient and easy to integrate panel mounted format using only 304 and 316L stainless steel with SwageLok™ compression fittings to ensure optimum sensor performance and longevity. With an integrated shelf for easy sensor calibration and maintenance, the Guardian PRO Boiler Feedwater Series was designed with the user in mind. The Guardian PRO IK-2000-PRO series boiler feedwater analyzer integrates up to four (4) unique Pyxis smart sensors. **\*NOTE\*** *The base model will come equipped with one ST-774 sensor only and all remaining pre-plumbed stainless tee assemblies are plugged for future use as the user desires.*

## 3. Features

- Fully Integrated & Turn-Key Boiler Feedwater Analyzer
- PowerPACK Pro-5 Auxiliary Power Supply, Display and Communication Module
- Reserved Space for Mounting of desired OEM Controller
- Pre-Configured Firmware to Enable up to 4 Pyxis Smart Sensors
- Pre-plumbed in fully stainless steel ¼-inch tubing with compression fittings
- Integrated Digital Sample Flow Meter and Manual Rotameter
- Integrated ST-774 Ultralow Dissolved Oxygen Sensor with Flow Cell
- Integrated stainless steel solenoid isolation valve for sample lockout on temperature alarm
- Three (3) Integrated ST-007 stainless steel inline Tee assemblies for up to 3 more Pyxis sensors
- Plug-N-Play sensor installation with pre-wired pigtails for future sensor addition.
- Integrated Sensor Calibration & Maintenance Shelf for user convenience

## 4. Description

**PowerPACK Pro-5:** The Pyxis PowerPACK Pro-5 intelligent adapter is uniquely designed to provide additional power budget and multiple communication methods to drive Pyxis inline sensors to a receiving microprocessor controller or PLC with limited power supply. This auxiliary adapter has a built-in power supply with 30-Watt capability and supports up to five Pyxis sensors connected simultaneously. The PowerPACK Pro-5 offers multiple communication platforms in both wireless and wired format to fit any application need. The wireless communication methods include Bluetooth® 5.0, LoRa and Wi-Fi and the wired communication methods include Ethernet, RS-485, 4-20mA output and USB-C. Users can choose the appropriate communication method according to the distance and application need. The PowerPACK Pro-5 is provided with a 2.4-inch display allowing users to manually configure any desired communication parameter as well as offering sensor reading or connection to the uPyxis 2.0 mobile or desktop apps. The PowerPACK Pro-5 intelligent adapter can be utilized in 100VAC to 240VAC power format, with direct outlet plug-in design. Each input is specifically designed for direct connection to standard (7-Pin) and with adapter connection to (8-pin) Pyxis inline sensors while the output is designed to be connected to the CS-FNS-2.6P (6-Pin) flying lead cable provided with the PowerPACK Pro-5 unit, then terminated to the receiving controller (see PowerPACK Pro-5 Cable Interface section for details). Conversion adapters for Pyxis 8-Pin sensors are also available allowing this device to be used with all Pyxis sensor formats.

**ST-774:** Provided on all versions of the Guardian PRO, the ST-774 is an ultra-low range dissolved oxygen (DO) sensor with a lower limit of detection 0.1 ppb ( $\mu\text{g/L}$ ). Its design is based on the principle of fluorescence quenching to determine the partial pressure of the dissolved oxygen in water and incorporates Pyxis' advanced technology in the field of fluorescence detection. The Pyxis ST-774 offers the robustness associated with optical DO sensor technology while achieving the ultra-low detection limit comparable to an amperometric DO sensor. The ST-774 measures the oxygen partial pressure that is at equilibrium with the dissolved oxygen in water governed by Henry's law ( $DO/ppb = K PO_2$ ). The ST-774 offers an easily replaceable, front loading DO membrane cartridge (DCC-2) that has been independently developed by Pyxis Lab, with a typical service life of up to 2-years. This sensor is also well known in the industry for its ability to be Zero-Calibrated in the field using the Pyxis Sulfite-ZERO calibration kit and the connected display terminal. The flat front-end design of the ST-774 makes this platform less prone to contamination or fouling and is very easy to clean. The sensor body and flow cell are composed of 316L stainless steel and is well suited for aggressive industrial application use.

**ST-765SS-SO3:** This sensor is provided with the Level 2 through 4 versions of the Guardian PRO along with the ST-774, or as an add-on sensor in the field. The ST-765SS-SO3 is a stainless-steel multi-parameter membrane-less sensor based on unique electrochemical principles to determine sulfite, pH, ORP and temperature of sample water. This sensor incorporates Pyxis' advanced technology in the field of bare-gold electrochemical detection. The ST-765SS-SO3 can simultaneously compensate for temperature and pH in the measurement of sulfite based on real-time conditions present in the application of use. This unique internal compensation results in a highly accurate sulfite measurement consistent with wet chemistry methodology commonly used for measurement of oxygen scavengers. This sensor may be calibrated while in service to the tested feedwater sulfite residual using a standard field drop test titration and the connected display/data logging terminal. The ST-765SS-SO3 sensor also offers a replaceable, front loading reference electrode assembly (EH-765) that has been independently developed by Pyxis Lab eliminating the shortcomings associated with membranes and gel replacement while offering reduced polarization time on startup with an electrode life span potential of up to 2-years. The ST-765SS-SO3 sensor body is composed of 304 stainless steel and is well suited for aggressive environments. This sensor is installed in one of the available stainless-steel ST-007 flow cells on the Guardian PRO analyzer panel. *Customized range of measurement available as optional service sold separately.*

**ST-525SS-T:** This sensor is provided with the Level 3 and 4 versions of the Guardian PRO along with the ST-774 and ST-765SS-SO3, or as an add-on sensor in the field. The ST-525SS-T is a newly designed stainless steel drop-in version of the well-known ST-525 inline fluorometer platform for the direct measurement of Fluorescein tracer utilizing LED light sources for use in industrial boiler feedwater. The new physical design of this sensor allows simple insertion into the stainless-steel ST-007 flow cell enabling easy sensor removal for cleaning and calibration. This sensor offers proprietary algorithms to determine the concentrations of Fluorescein at levels as high as 60ppb and resolution of 0.1ppb, while simultaneously measuring light loss through the optical channel to determine sensor cleanliness. After cleanliness has been verified, this sensor may be slope calibrated using Pyxis Fluorescein calibration standard solutions and the connected display terminal. *Customized range of measurement available as optional service sold separately.*

**ST-724:** This sensor is provided with the Level 4 version of the Guardian PRO, along with ST-774, ST-765SS-SO3 and ST-525SS-T, or as an add-on sensor in the field. The ST-724 provides a unique electrode design using a Hastelloy liquid end with integrated temperature and RTD compensation offering precision accuracy in ultra-low to low range conductivity waters with a range of detection from 0.02 to 1,000  $\mu\text{S}/\text{cm}$ . User conversion programming for display as TDS (Total Dissolved Solids) is also fully integrated into the Guardian PRO boiler feedwater series display interface. The addition of ST-724 to the Guardian PRO analyzer makes boiler cycles of concentration a measurable value when used with an existing boiler blowdown controller. *Customized range of measurement available as optional service sold separately.*

## 5. Pyxis Guardian PRO Hardware & Display Features

- The Guardian PRO boiler feedwater series comes equipped with three (3) pre-mounted ST-007 Single-Sensor inline stainless steel flow cells as well as (1) ST-774 flow stainless steel flow cell. The sample plumbing is 316L stainless steel with SwageLok fittings in ¼-inch OD compression. The Guardian PRO analyzer is also equipped with inline rotameter (100-500ml/min), solenoid sample temperature lockout valve and digital Hall-Effect inlet flow meter for precise sample flow measurement and control recommended at 100-500 mL/minute with a maximum inlet pressure suggested of 30psig. The outlet flow should be diverted to drain or the inlet of the pretreatment system for those desiring recovery (i.e. condensate return tank).

**\*IMPORTANT NOTE\*** *The Pyxis Guardian PRO requires installation downstream of an inline sample cooler with sample effluent to atmospheric drain or lower pressure zone of feedwater storage. Sample water temperatures should be maintained at or below 120°F (49°C) and pressure at or below 30psig.*

- Each Guardian PRO boiler feedwater analyzer comes equipped with the Pyxis CloudLink™ 4G Gateway and global SIM Card in deactivated mode. This gateway may be activated by Pyxis Lab upon user request and annual enrollment, allowing for wireless data transmission to any cloud data management platform, including Pyxis Cloud™. Contact [service@pyxis-lab.com](mailto:service@pyxis-lab.com) for more information.
- Convenient and simple to install back-panel with integrated sensor calibration & maintenance shelf for rapid installation and convenience of use. Truly a plumb and power to go platform with intense factory setup, testing and sensor calibration prior to shipment.

### Pyxis Guardian PRO Versions (Sensors Included)

Item	Guardian PRO IK-2000-PRO (Level 1)	Guardian PRO IK-2010 Pro (Level 2)	Guardian PRO IK-2020 Pro (Level 3)	Guardian PRO IK-2030 Pro (Level 4)	Guardian PRO IK-2040 Pro (Level 5)
<b>P/N</b>	45050	48852	41319	45232	47516
<b>ST-774</b> (Dissolved Oxygen + Temperature)	Included	Included	Included	Included	No Sensors Included – All Tees Plugged for Individual Sensor Add Later If Desired
<b>ST-765SS-SO3</b> (Sulfite + pH + ORP)	Add Later If Desired	Included	Included	Included	
<b>ST-525SS-T</b> (Fluorescein Tracer)	Add Later If Desired	Add Later If Desired	Included	Included	
<b>ST-724</b> (Conductivity + TDS)	Add Later If Desired	Add Later If Desired	Add Later If Desired	Included	

**\*NOTE\*** The Guardian PRO Boiler Feedwater Analyzer panel design is identical for all 5 levels allowing users to purchase the base level 1 and later purchase and install as desired the additional Pyxis sensors without the need for equipment upgrade, configuration or replacement. Customized range of measurements for specific sensors are available as an optional service sold separately

## Order Information

	P/N
Guardian PRO Boiler Feedwater IK-2000-PRO <i>(PowerPACK PRO-5 + DO + Temperature + 3-Unused ST-007 Flow Cells)</i>	45050
Guardian PRO Boiler Feedwater IK-2010-PRO <i>(PowerPACK PRO-5+ DO + SO3 + pH + ORP +Temperature + 2-Unused ST-007 Flow Cells)</i>	48852
Guardian PRO Boiler Feedwater IK-2020-PRO <i>(PowerPACK PRO-5 + DO + SO3 + pH + ORP +Temperature + Fluorescein + 1-Unused ST-007 Flow Cell)</i>	41319
Guardian PRO Boiler Feedwater IK-2030-PRO <i>(PowerPACK PRO-5 + DO + SO3 + pH + ORP +Temperature + Fluorescein + Conductivity)</i>	45232
Guardian PRO Boiler Feedwater IK-2040-PRO <i>(PowerPACK PRO-5 + Complete Panel Plumbed with Empty Tee's No Sensors Included)</i>	47516

## Optional / Replacement Accessories Information

	P/N
PowerPACK PRO-5 <i>(Five Channel Power Supply with Display and I/O 100-240VAC)</i>	MA-PS-5
ST-774 <i>(Ultra-Low Luminescent Dissolved Oxygen + Temp. Sensor 0.1-2,000ppb – Stainless Steel)</i>	53715
ST-774 SERVICE SWAP <i>(Annual swap out of ST-774 for Pyxis Factory Serviced &amp; Calibrated Unit)</i>	ST-774-SWAP
ST-765SS-SO3 <i>(Sulfite + pH + ORP Sensor w/Internal Compensation 0-100ppm – Stainless Steel)</i>	53624
ST-525SS-T <i>(Fluorescein Sensor w/Internal Compensation 0-60ppb – Stainless Steel)</i>	56553
ST-724 <i>(Ultra-Low Conductivity + Temp. Sensor 0.02 – 1,000 µS/cm – Stainless Steel)</i>	10009
DCC-2 <i>(Replacement Luminescent Cartridge Cap for ST-774)</i>	53716
EH-765 <i>(Replacement Electrode Head for ST-765SS-SO3)</i>	53061
Solenoid Valve <i>(Stainless Steel Electric Sample Temperature Isolation Valve – ¼-inch Compression)</i>	21452
Stainless Steel Hall Effect Flow Meter <i>(Pulse Flow Meter ¼-inch Compression 0.1 - 2.5L/Min)</i>	22501
Micro-Rotameter Assembly Kit <i>(Replacement Rotameter Assembly Kit 100-500ml/min)</i>	24387
ST-774 Flow Cell <i>(Replacement Stainless Steel Flow Cell for ST-774 ¼-inch Compression)</i>	53718
ST-007 <i>(Replacement Stainless Steel Flow Cell for ST-765SS-SO3 / ST-525SS-T / ST-724 Sensors)</i>	50700-A51
Replacement Temperature Gauge	29098
Replacement Pressure Regulating Valve with Gauge	27439
ST-002-S Stainless Steel PLUG <i>(Replacement Plug for Unused Flow Cells)</i>	21629
Sulfite-ZERO Calibration Kit <i>(Sensor Cap &amp; Catalyzed Sulfite w/Vial for ST-774 Zero Calibration)</i>	16019
Pyxis SO2LI -Sulfite Low Range Reagent Kit <i>(using Pyxis SP800/SP910 for sensor calibration)</i>	30604
Pyxis pH Combo Calibration Pack <i>(pH 4-7-10 Calibration Solution 3-Pack - 500mL ea.)</i>	57007
Pyxis ORP-200 <i>(ORP-200mV Calibration Solution – 500mL ea.)</i>	57020
Pyxis FLUO-10 <i>(Fluorescein Calibration Solution – 10ppb – 500mL ea.)</i>	FLUO-10
Pyxis FLUO-20 <i>(Fluorescein Calibration Solution – 20ppb – 500mL ea.)</i>	FLUO-20
Pyxis Conductivity Calibration Std – 100 µS/cm <i>(500mL)</i>	39047
Pyxis Conductivity Calibration Std – 1,000 µS/cm <i>(500mL)</i>	57008

## 6. Analyzer Dimension and Mounting

### 6.1. Analyzer Dimension

Level 1 - Guardian PRO Boiler Feedwater IK-2000-PRO Dimensions (mm)

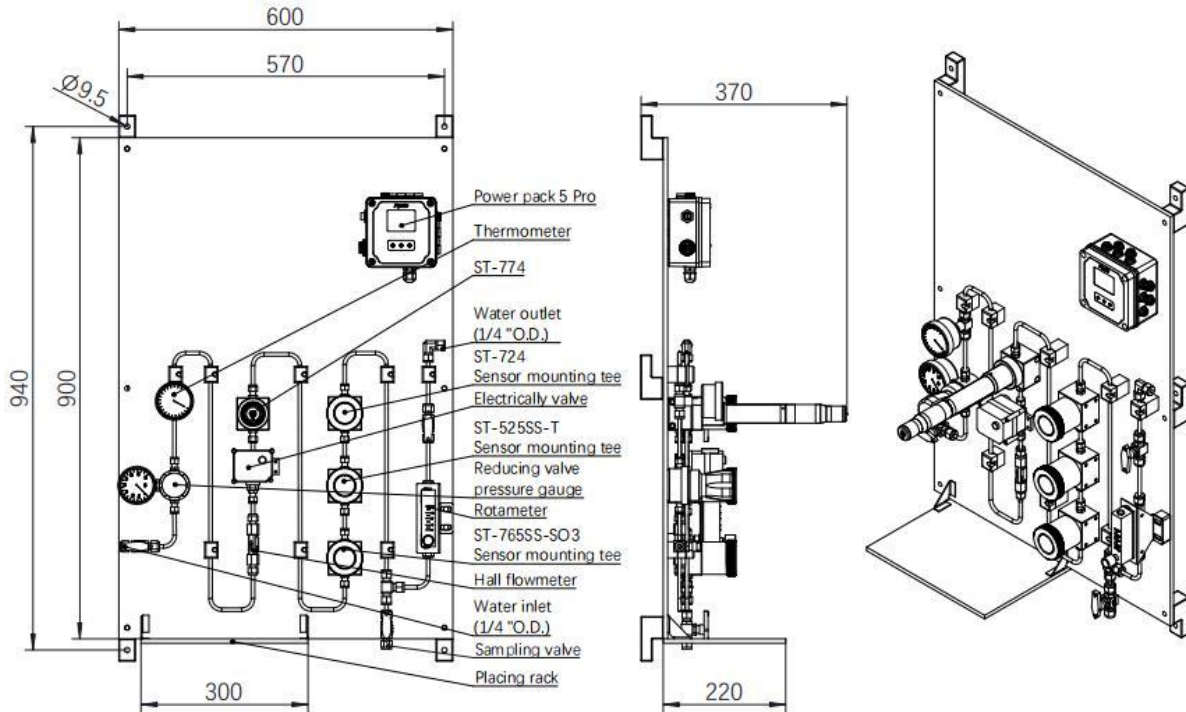

Level 2 - Guardian PRO Boiler Feedwater IK-2010 Pro Dimensions (mm)

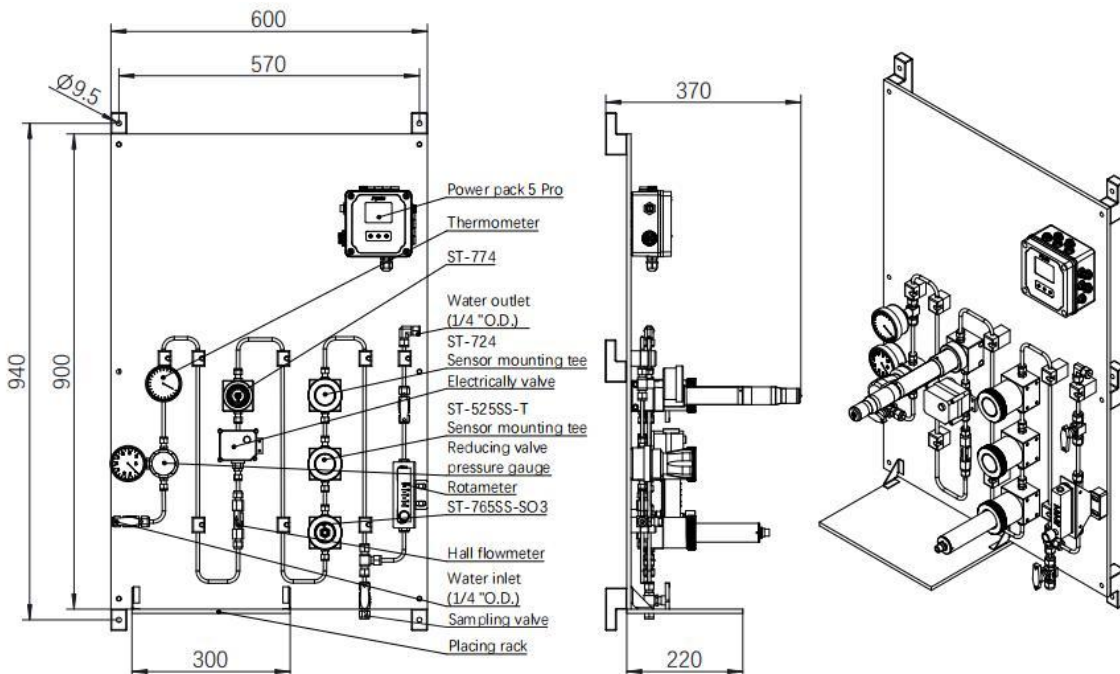

**Level 3 - Guardian PRO Boiler Feedwater IK-2020 Pro Dimensions (mm)**

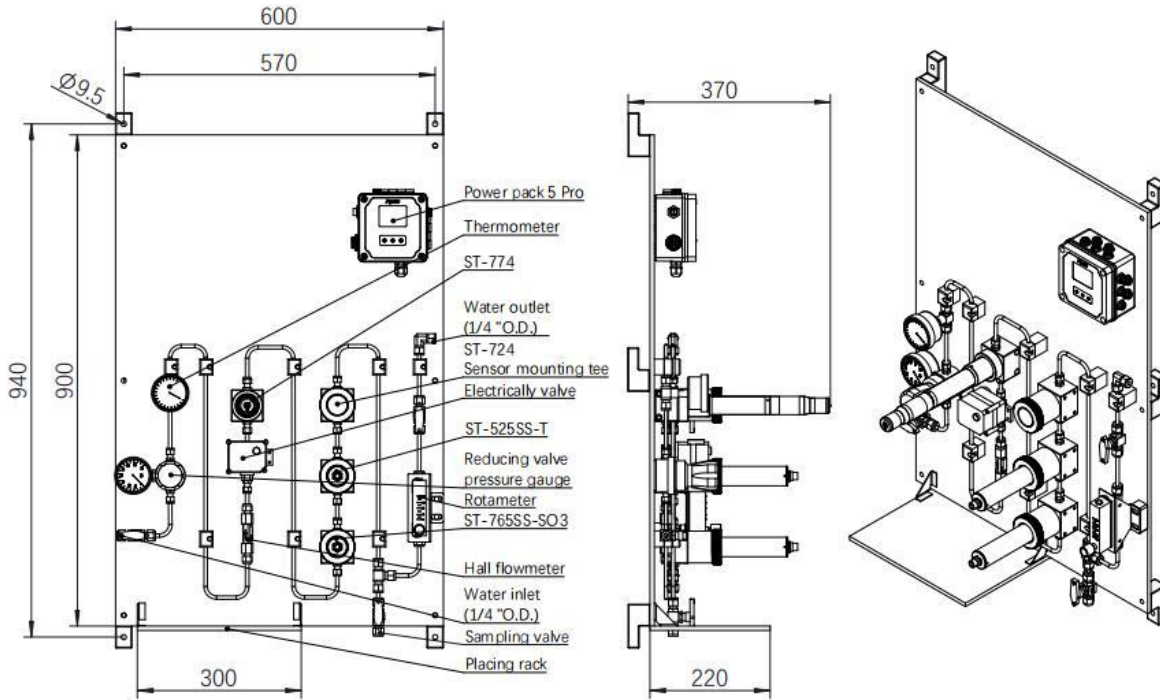

**Level 4 - Guardian PRO Boiler Feedwater IK-2030 Pro Dimensions (mm)**

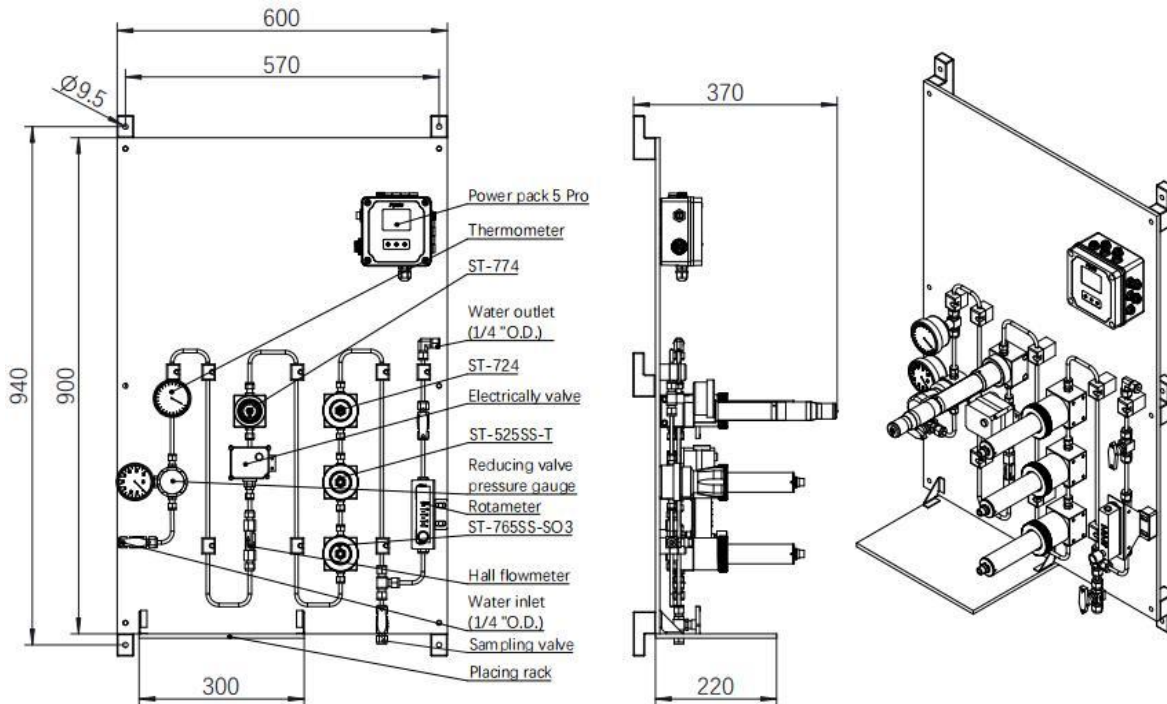

Level 5 - Guardian PRO Boiler Feedwater IK-2040 Pro Dimensions (mm)

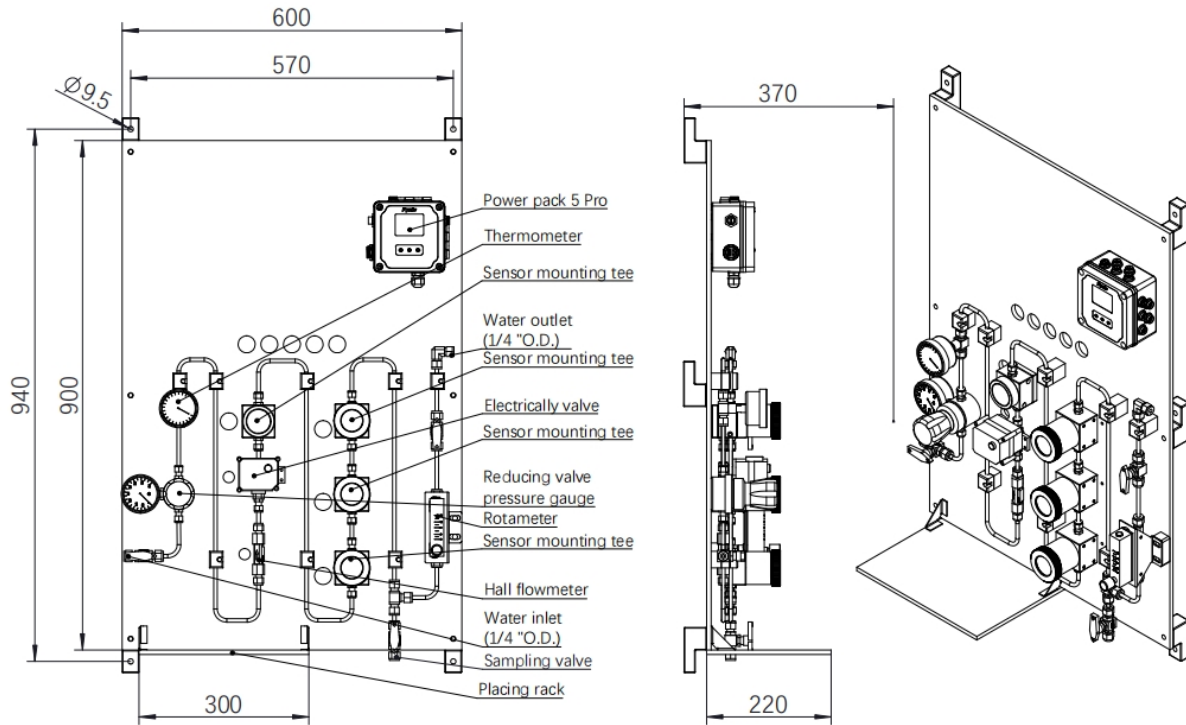

PowerPACK Pro-5 Dimensions (mm)

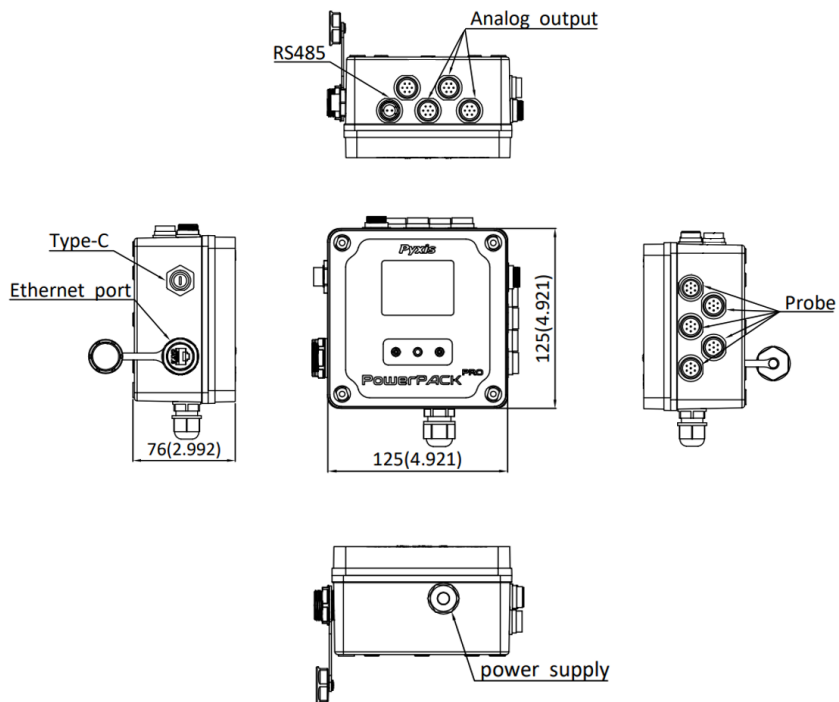

ST-774 Sensor Diagram (mm)

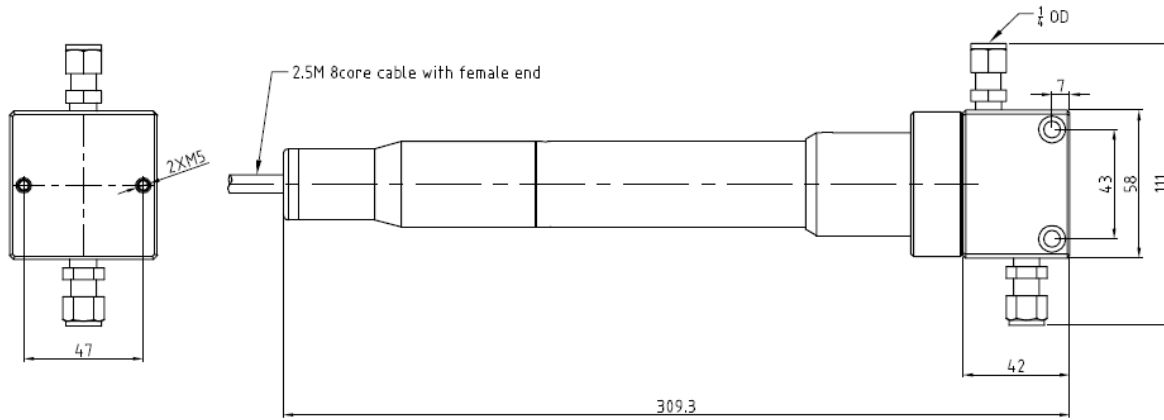

ST-765SS-SO3 Sensor Diagram (mm)

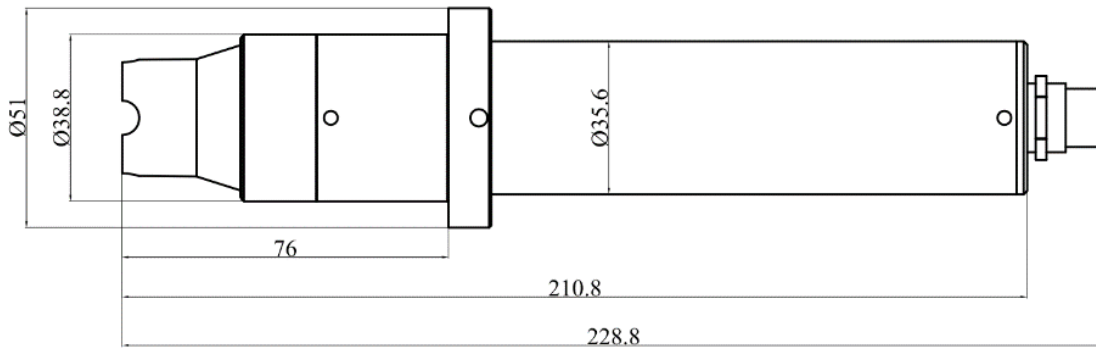

ST-525SS-T Sensor Diagram (mm)

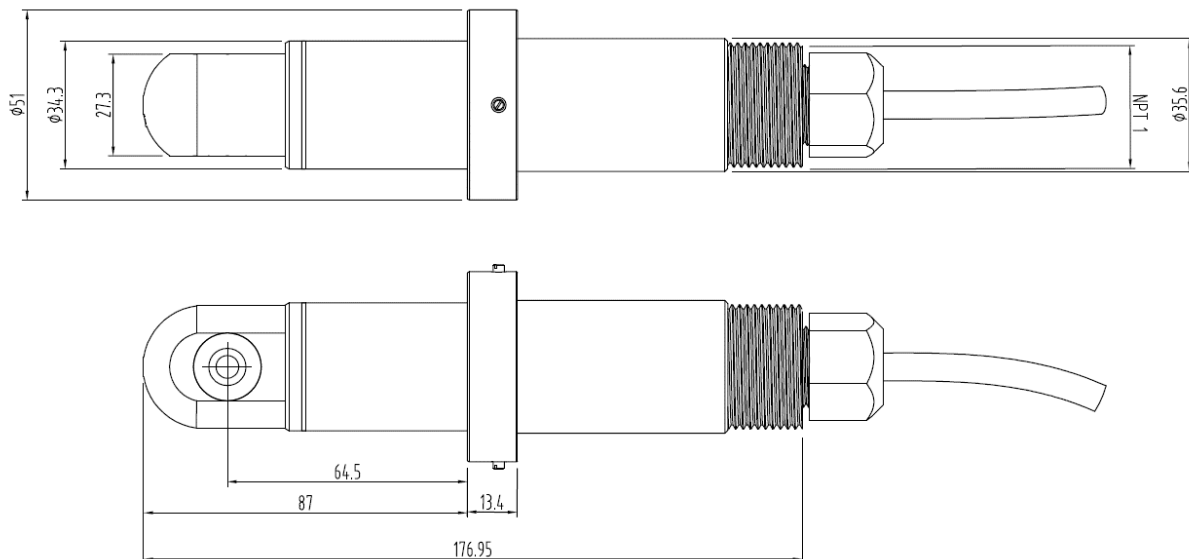

ST-724 Sensor Diagram (mm)

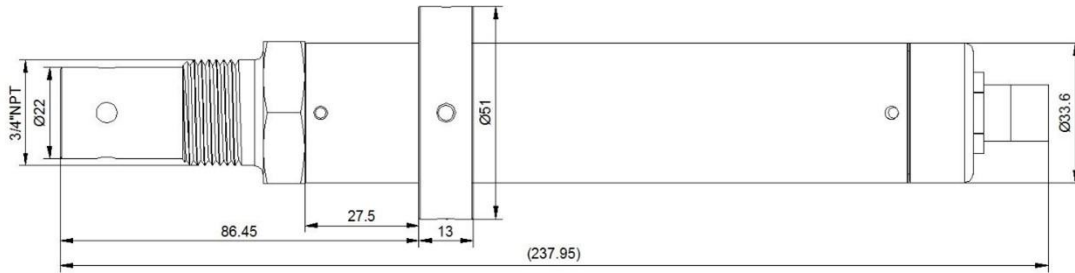

ST-007 Stainless Steel Tee Assembly Diagram

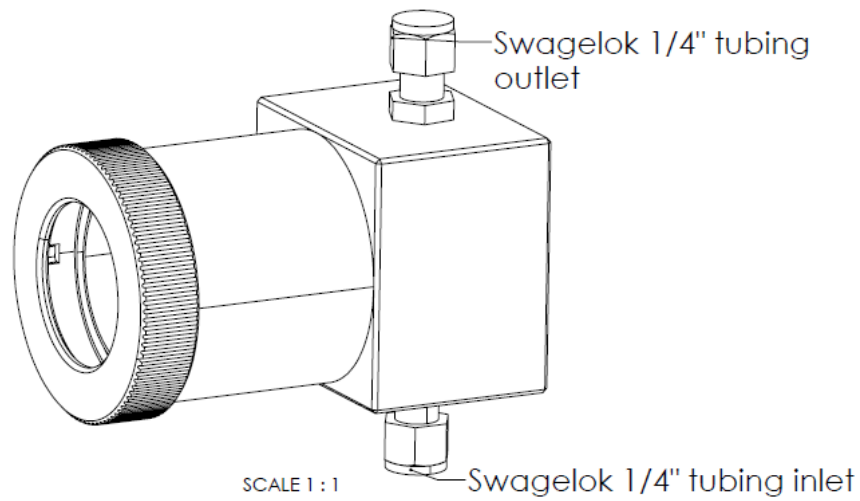

## 6.2. Analyzer Installation & Component Pressure/Temperature Ratings

### 6.2.1. Analyzer Component Pressure & Temperature Ratings

Please refer to the table below for maximum operating pressure and temperature of the Guardian analyzer components.

Item Name	Max Operating Pressure	Max Operating Temp
Inlet Pressure Regulator Valve	2900 psi	165F
Inlet Pressure Gauge	232 psi	165F
Temperature Gauge	232 psi	210F
Hall Effect Flow Meter	253 psi	140F
Solenoid Valve Cutoff	145 psi	212F
MicroRotameter After Cutoff	87 psi	140F
Inlet Isolation Valve	2900 psi	842F
ST-774 Sensor	145 psi	122F
ST-765SS-SO3 Sensor	100 psi	120F
ST-525SS-T Sensor	290 psi	120F
ST-724 Sensor	100 psi	120F

### 6.2.2. Installation Requirements

**Power Supply:** 100-240V AC (50/60Hz) w/3.0 AMP Fuse

**Inlet Water Supply:** The inlet water pressure should be from 7.25 – 30 psi (0.05 – 0.2Mpa)

**Outlet Water Line:** This line should be returned to atmospheric sump or lower pressure section of the analyzed system water network.

**Wall Mount Space:** Please leave at least 0.5m of installation space around the equipment for later maintenance.

**Wall Mount Weight:** Approximately 25kg. Please use appropriate mounting hardware.

### 6.2.3. Sample Water Connections

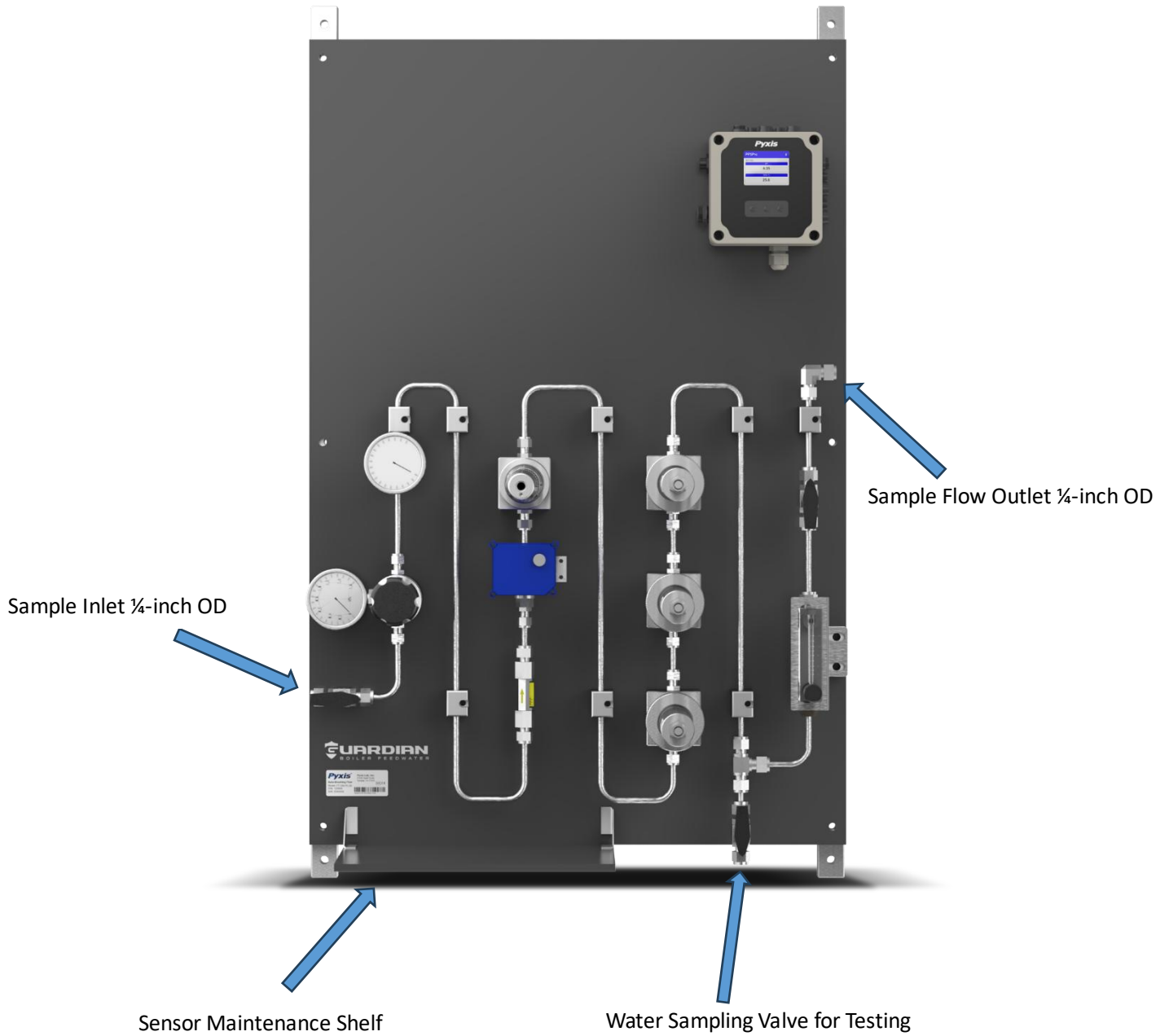

### 6.3. Flowmeter and Electric Isolation Valve

#### 6.3.1. Flowmeter Specifications & Wiring

Item	Stainless Steel Flow Sensor
Model ID	MJ-HZ41WD
P/N	22501
Material	SUS304
Water Pressure	<1.75MPa
Sample Temperature	≤60°C (Water Only)
Inlet/Outlet Size	G1/4" male thread
Operating Voltage	DC 5-24V
Flow Range	0.1 - 3L/min
Maximum Operating Current	15mA
Insulation Properties	Insulation Resistance >100MΩ
Electric Strength	AC500V 50Hz
Cumulative Pulse	When the flow rate is 1.0L/min, 1L water = 7516pulse ± 10%
Wiring	Red (+)
	Black (-)
	Yellow (Pulse)

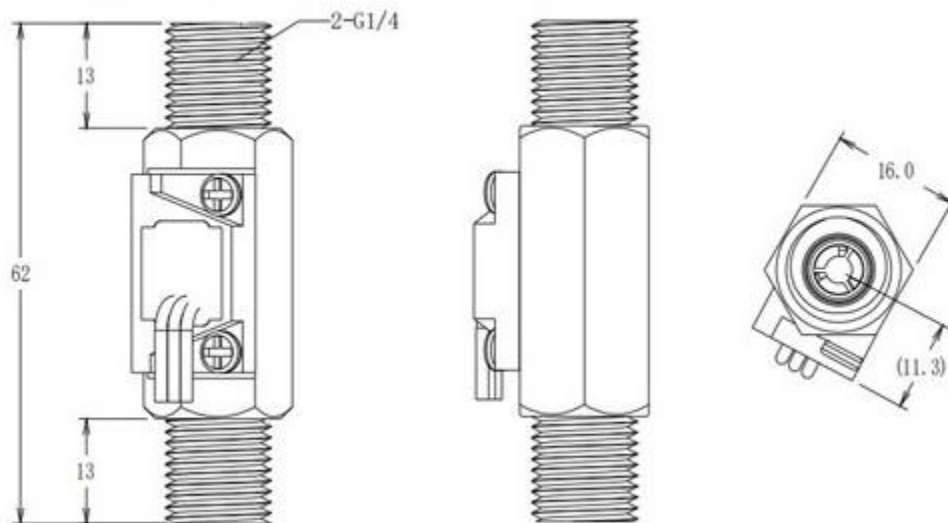

### 6.3.2. Electric Sample Isolation Valve Specifications & Wiring

Item	Electric Valve
Operating Voltage	DC 24 V
Voltage Range	DC 22-26 V
Operating Current	≤250 mA
Quiescent Current	15±3 mA
Maximum Power Consumption	5 W
Running Time	5 s
Fuse Specification	2 A
Turning Angle	90 ± 2°
Noise Level	Max. 75 dB(A)
Class of Protection	IP67 En60529/GB4208-2008
Insulation Resistance	100 MΩ/500 VDC
Ambient Temperature	-15 °C < t < 45 °C
Ambient Humidity	Relative Humidity ≤ 85% (non-condensation)
Valve Diameter	1/2" NPT
Medium Pressure	1.0 Mpa
Valve Body Material	SS304
Ball Material	SS304
Service Life	70,000 Actuations

#### Wiring of Electric Sample Isolation Valve

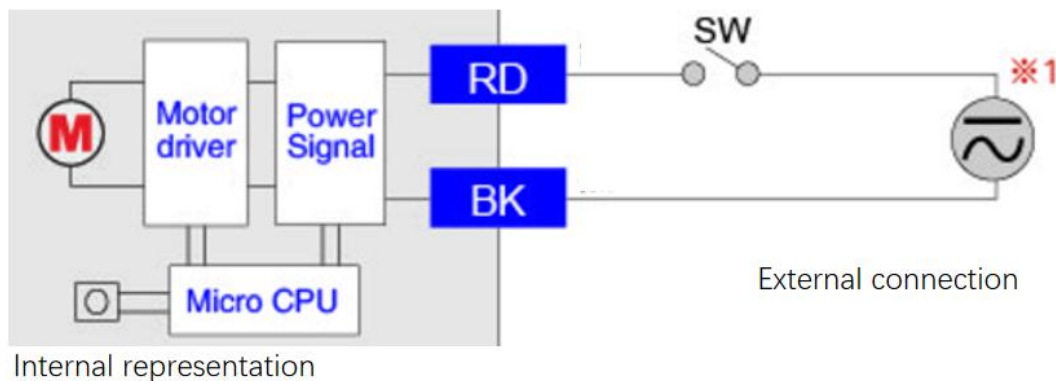

#### Normally Open Type (NO)

1. The SW is closed, the electric valve is closed, and it is kept after being closed.
2. SW disconnect, electric valve open, open in place to keep.

**\*IMPORTANT NOTE\*** When powered on (Valve Closed Position), the minimum power on time should be greater than 60s, so as to ensure that the charging amount of the internal energy storage components is sufficient for powering off (Valve Open Position) and reset. When the charging is insufficient, the power reset may stop if it is not in place.

## 7. PowerPACK Pro-5 Operation Guide

### 7.1. Electrical Connection

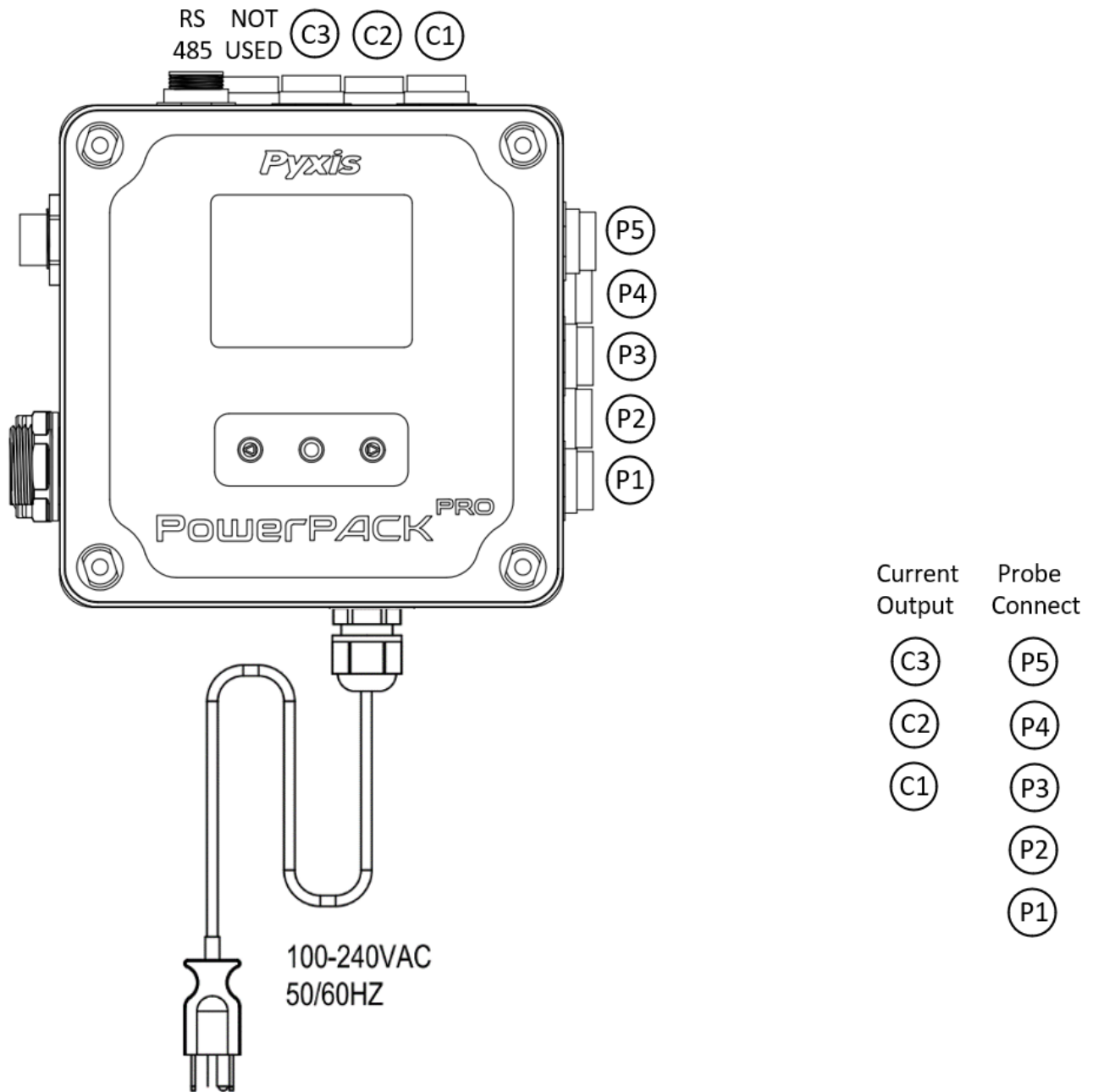

Figure. 1

### RS-485 Output (TOP LEFT 2-PIN ADAPTER)

Cable Provided	Description
CR-MR-2.6P (P/N 16297)	Flying Lead Cable / 2Pin Male
Wire Color	Designation
Blue	RS-485 A
Yellow	RS-485 B

**\*NOTE\*** Contact [service@pyxis-lab.com](mailto:service@pyxis-lab.com) for Modbus Register details on the sensors utilized in RS-485.

### C1 4-20mA Current Output (TOP RIGHT 7-PIN ADAPTER)

Cable Provided	Description
CS-FNS-2.6P (P/N 10891)	Flying Lead Cable / 7Pin Female
Wire Color	Designation
Black	4-20mA - Common
White	#1 4-20 mA+ Corresponding Pyxis probe 1
Green	#2 4-20 mA+ Corresponding Pyxis probe 1
Blue	#1 4-20 mA+ Corresponding Pyxis probe 2
Yellow	#2 4-20 mA+ Corresponding Pyxis probe 2
Silver	Earth Ground

### C2 4-20mA Current Output (TOP RIGHT 7-PIN ADAPTER)

Cable Provided	Description
CS-FNS-2.6P (P/N 10891)	Flying Lead Cable / 7Pin Female
Wire Color	Designation
Black	4-20mA - Common
White	#1 4-20 mA+ Corresponding Pyxis probe 3
Green	#2 4-20 mA+ Corresponding Pyxis probe 3
Blue	#1 4-20 mA+ Corresponding Pyxis probe 4
Yellow	#2 4-20 mA+ Corresponding Pyxis probe 4
Silver	Earth Ground

### C3 4-20mA Current Output (TOP RIGHT 7-PIN ADAPTER)

Cable Provided	Description
CS-FNS-2.6P (P/N 10891)	Flying Lead Cable / 7Pin Female
Wire Color	Designation
Black	4-20mA - Common
White	#1 4-20 mA+ Corresponding Pyxis probe 5
Green	#2 4-20 mA+ Corresponding Pyxis probe 5
Blue	Not used
Yellow	Not used
Silver	Earth Ground

## 7.2. Corresponding Sensor 4-20mA Output Assignments & Ranges for PowerPACK Output

Each Pyxis sensor on the Guardian will contain up to two (2) 4-20mA outputs when adapting to the input of the PowerPACK Pro-5. It is important to understand which the correct assignment of 4-20mA output from the sensor so that users can properly select the output flying lead wire exiting the PowerPACK Pro-5 for connection to their OEM Controller as output wire colors are altered based on the tables provided in Section 8.1

**\*IMPORTANT NOTE\*** Please refer to the table below for the corresponding 4-20mA #1 and #2 (if applicable) details when determining corresponding PowerPACK PRO-5 output signal alignment. Contact [service@pyxis-lab.com](mailto:service@pyxis-lab.com) for support.

Sensor Name	#1 4-20mA+	#2 4-20mA+
ST-774	Dissolved Oxygen (0 – 2,000ppb)	Temperature (32 – 122F)
ST-765SS-SO3	Sulfite (0-100ppm)	pH (0-14)
ST-525SS-T	Fluorescein (0-60ppb)	NA
ST-724	Conductivity (0-1,000uS/cm)	Temperature (32-212F)

**P1 – P5 Pyxis Sensor Plug-In (SIDE RIGHT 7-PIN ADAPTER)**

For Pyxis 7-Pin Sensors, Connect directly to PowerPACK Pro-5

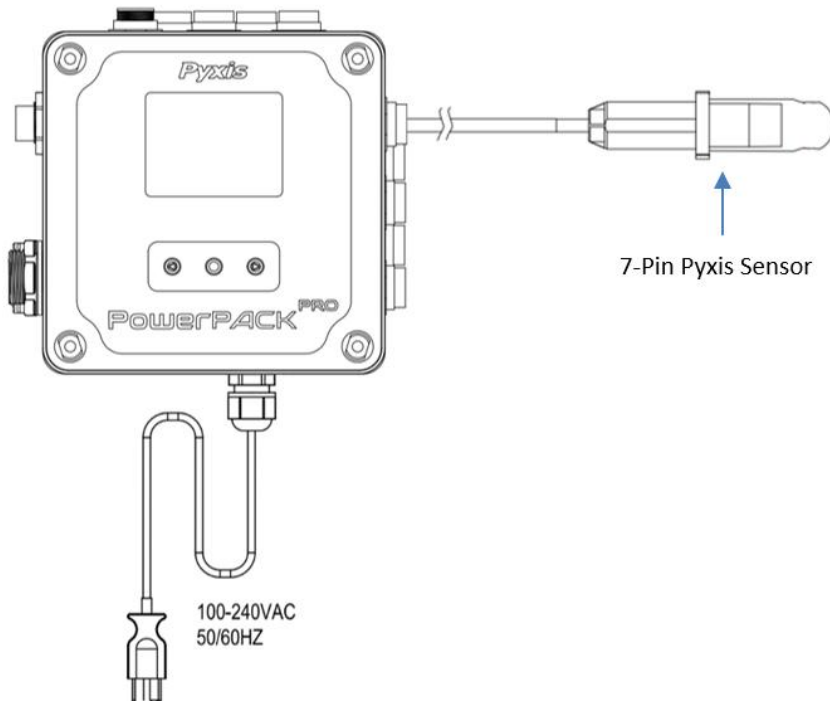

Figure. 2

For Pyxis 8-Pin Sensors, using the **CC-78M** Conversion Adapter to connect to PowerPACK 5Pro.

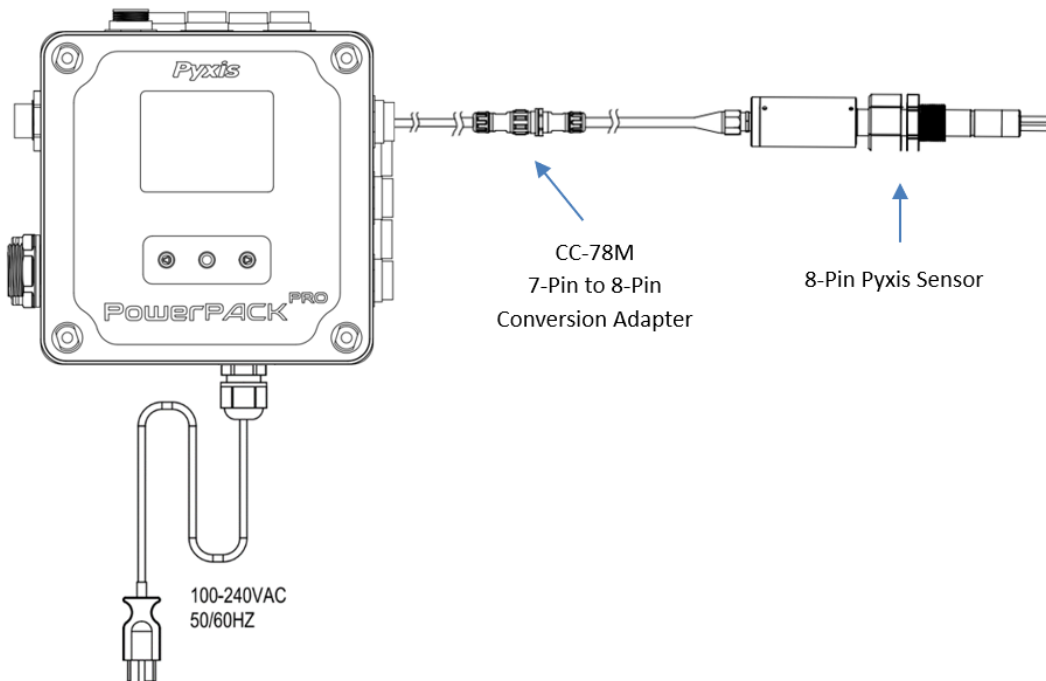

Figure. 3

### 7.3. PowerPACK Pro-5 Quick Start-up Procedure

#### 7.3.1. Keys

- ◀▶ Up / Down key - Select different parameters or
  - adjust displayed values or
  - change page in **main screen**
- OK key - Confirm parameter changes or
  - from **main screen** enter **setup menu**

#### 7.3.2. Device Power-up & Sensor Scanning

When PowerPACK Pro-5 is powered on, a scanning screen will be displayed. In this screen, the PowerPACK Pro-5 will automatically do a scan and display a list of available (connected) Pyxis sensors. **\*NOTE\*** To stop scanning, please press the ● button; to continue scanning, please press the ▶ button; to restart the scanning, please press the ◀ button.

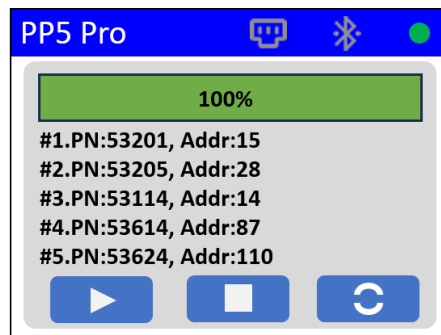

Figure. 4 Scanning Screen

**\*IMPORTANT NOTE\* RS-485 Bus Conflict\*** It is critical to ensure that each slave device (Pyxis sensor) in an RS-485 network has a unique modbus address (Addr). If connecting multiple Pyxis sensors of the same model (P/N) to the PowerPACK Pro-5, an address conflict will occur. They should be identified and resolved promptly by modifying the duplicate addresses to ensure that each device can correctly respond to the host's (PowerPACK Pro-5) requests. Therefore, if multiple sensors of the same model are connected, see section 5.1.2 Reassigning Slave Address.

When the scanning progress reaches 100%, the PowerPACK Pro-5 will automatically jump to the main screen.

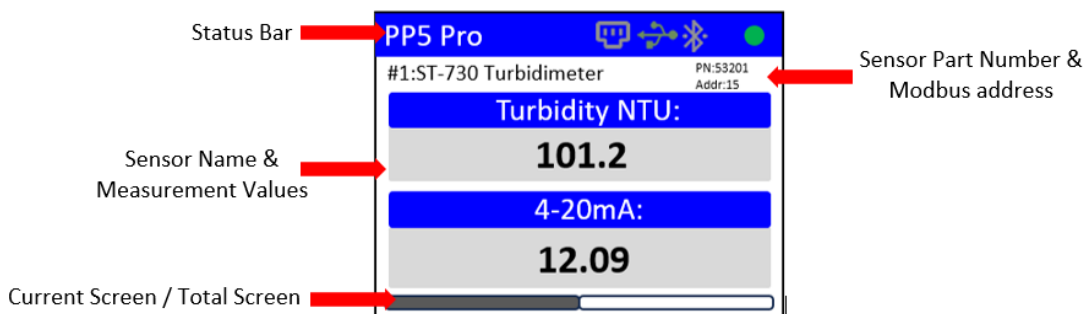







Figure. 5 Main Screen

### 7.3.3. Status Bar Symbols

Symbol	Description
	<b>Ethernet</b> , This icon flashing indicates that the Ethernet configuration is being updated. Please wait until it stops flashing before accessing Ethernet.
	<b>Bluetooth</b> , allows communication with <b>uPyxis</b> <sup>®</sup> mobile & <b>uPyxis</b> <sup>®</sup> desktop This icon turns <b>green</b> when connected to <b>uPyxis</b> <sup>®</sup>
	<b>USB</b> , appears when connected to PC
	<b>Run Status</b> ,  flashing indicates that the PowerPACK-Pro is operating normally

### 7.3.4. Hiding the Sensor Reading

Main Screen → Setup Menu → Monitor

Users can hide the sensor readings by disabling the monitoring mode.

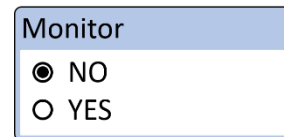

After disabling the monitoring mode the main screen will be shown as below.

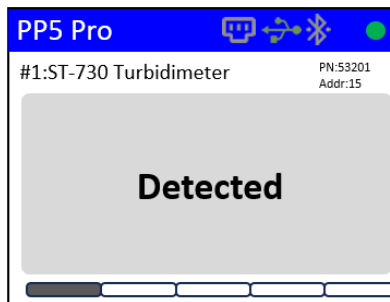

Figure. 6

### 7.3.5. Ethernet Settings

Main Screen → Setup Menu → Ethernet

Figure 7 shows the **Ethernet** menu.

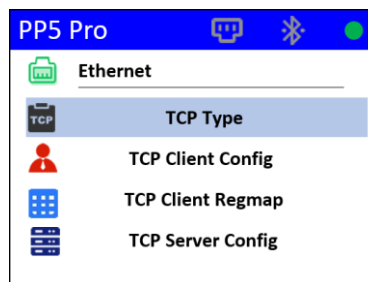

Figure. 7

The default Ethernet Settings for PowerPACK Pro-5 are as follows:

TCP Type:	TCP Server
IP Address:	192. 168.0.7
Subnet Mask:	255.255.255.0
Gateway IP:	192.168.0.1

### TCP Server Configuration

This section demonstrates how to set up PowerPACK Pro-5 as a TCP server, and the computer as a TCP client to access PowerPACK and obtain sensor values.

#### Setting Procedure:

1. Navigate to Ethernet Menu and select TCP Type.
2. Select TCP Server in the options box.

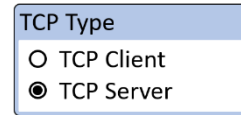

3. Select TCP Server Config from the Ethernet menu.
4. Select the Method for Obtaining IP Addresses.

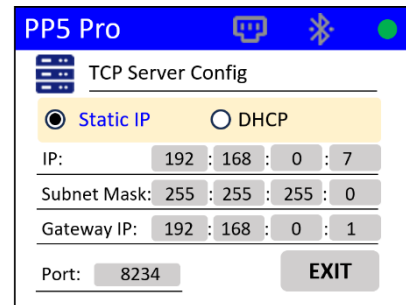

**\*NOTE\*** If you choose the Static IP, you need to set the IP, Subnet Mask, Gateway IP and Port manually. Generally, users will keep the default Settings

If you choose **DHCP**, you only need to enter the **Port** number.

5. Connect the PowerPACK Pro-5 RJ-45 port to your computer with an Ethernet cable, and set your computer IP address to 192.168.0.x, make sure the PowerPACK and computer are on the same network subnet. For example, if the IP address of the PowerPACK Pro-5 is 192.168.0.7, the IP address of the computer may be 192.168.0.x (where x can be any number between 1 to 250), according to Figure 10. **\*NOTE\*** Please leave Default gateway blank.

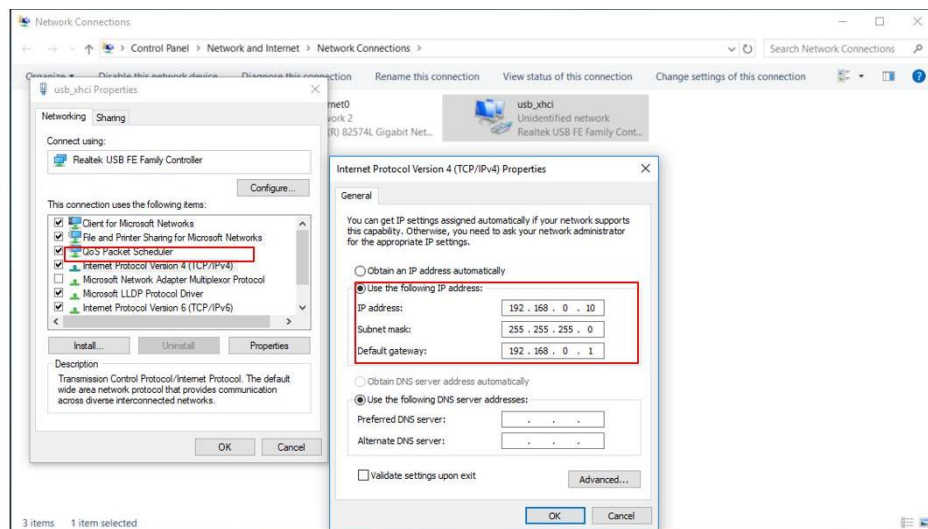

Figure. 8

6. Access PowerPACK Pro-5 using Modbus host software (here used **Modbus Poll** as an example). As shown in figure 9, enter the IP address and Port number of the PowerPACK Pro-5.

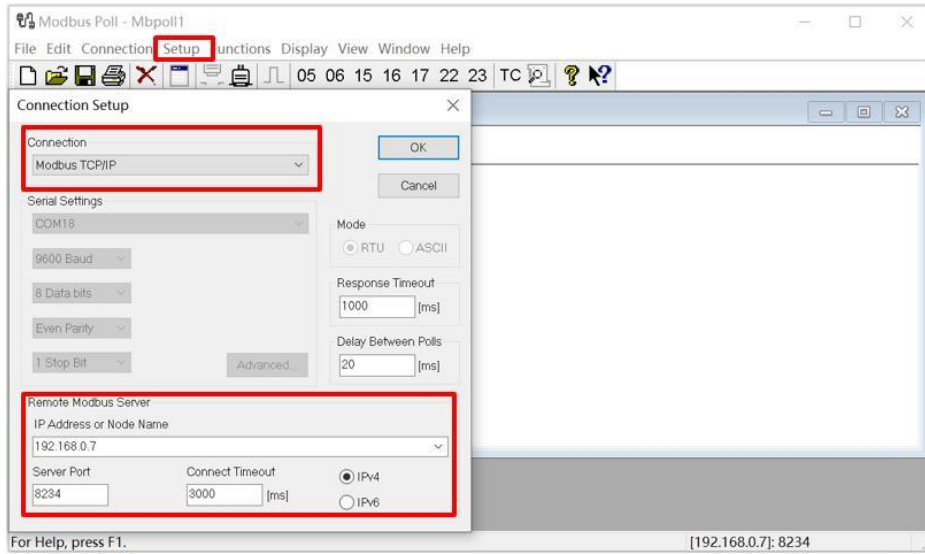

Figure. 9

7. View the sensor reading by accessing the specified register address (please refer to [Pyxis Sensor Modbus Communication Manual](#)).

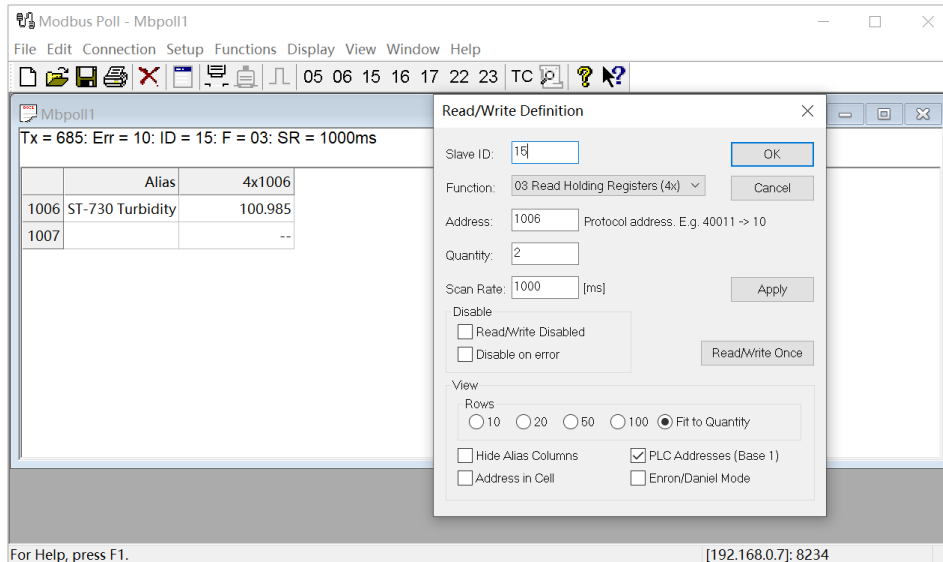
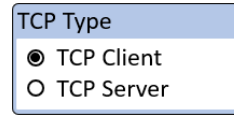

Figure. 10

### TCP Client Configuration

This section will demonstrate how to set up the PowerPACK Pro-5 as a TCP Client and the computer as a TCP server to follow the PowerPACK and obtain sensor values.

1. Navigate to **Ethernet menu** and select **TCP type**
2. Select **TCP Client** in the options box
3. Select TCP Client Config from the Ethernet menu.
4. In **TCP Client Config** screen, you can specify an IP address for your computer, as shown in figure 11, make sure the PowerPACK and computer are on the same network subnet. For example, if the IP address of the PowerPACK Pro-5 is 192.168.0.10, the IP address of the computer may be 192.168.0.x (where x can be any number between 1 to 250).



**\*NOTE\*** Generally users keep the default TCP client Settings.

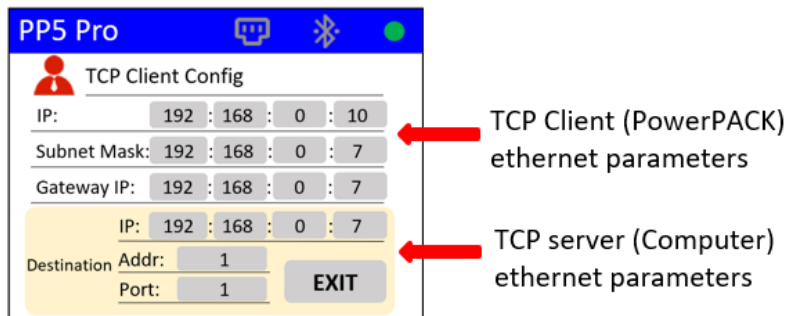

Figure. 11

5. Connect the PowerPACK Pro-5 RJ-45 port to your computer with an Ethernet cable and set your computer IP address according to the TCP server IP address, as shown in figure 11.

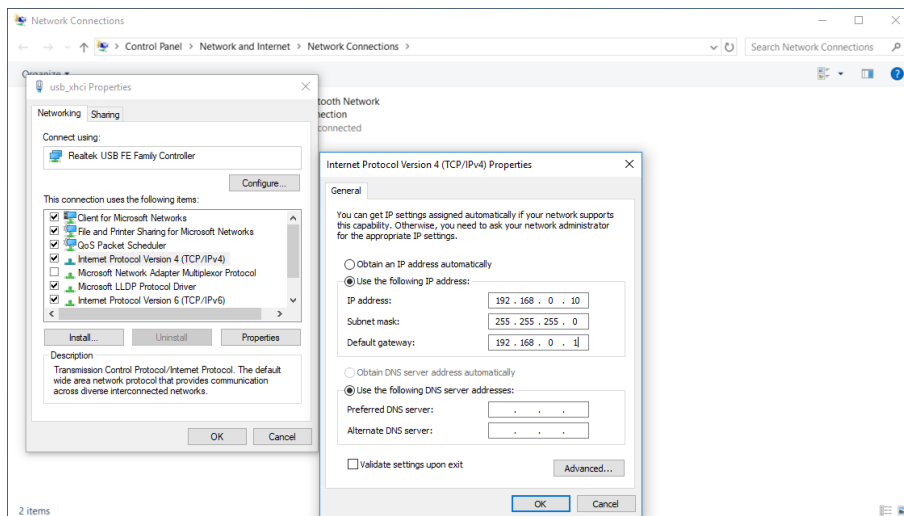

Figure. 12

- Access PowerPACK Pro-5 using Modbus Slave software (here used **Modbus Save** as an example). As shown in figure 13, enter the IP address and Port number of the computer.

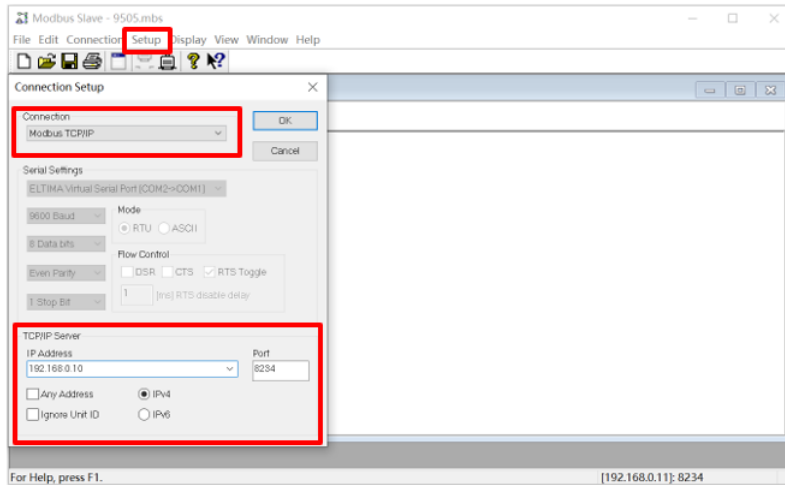

Figure. 13

- Select TCP Client Register Map from the Ethernet Menu. This page shows the register address which will be accessed in Step 8

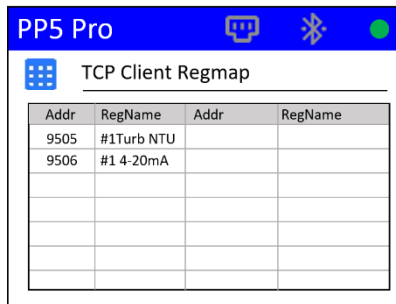

Figure. 14

- View the sensor reading by accessing the specified register address

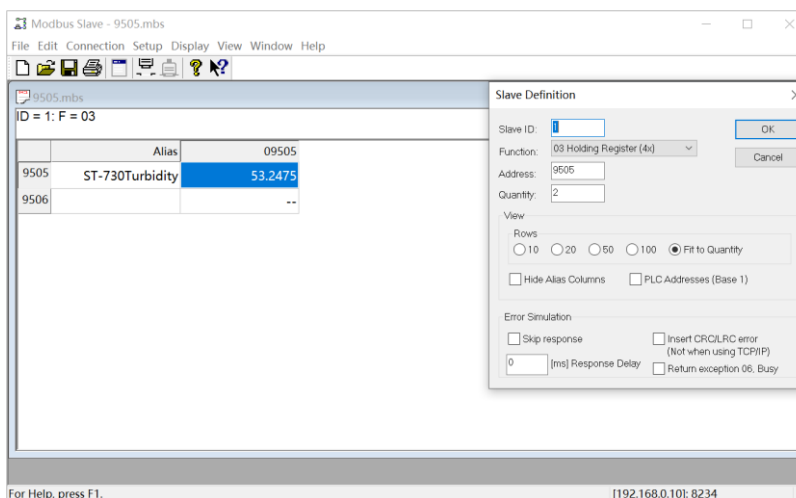

Figure. 15

### 7.3.6. Device Information

Main Screen → Setup Menu → Device Info

Figure 16 page shows the current **Ethernet** communication parameters. Please follow these settings when using **Modbus TCP**

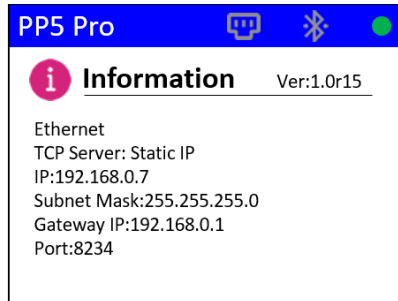

Figure. 16

## 7.4. Sensor Setup & Calibration Using PowerPACK Pro-5 Local Display

### 7.4.1. Sensor Configuration

Main Screen → Setup Menu → Probe Option → Select Sensor# → Configuration

The PowerPack Pro-5 provides a calibration feature, allowing each channel's sensor to be independently configured and calibrated.

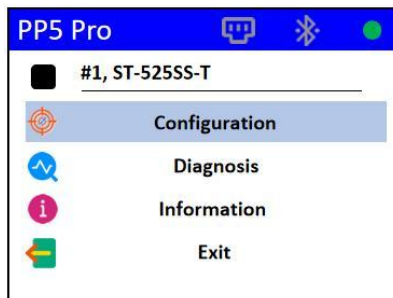

Figure. 17



Figure. 18

### Sensor Calibration, 4-20mA Span & Restore Default Calibration Parameters

Using the ST-525SS-T sensor as an example, the user can perform calibrations by selecting **DI CAL** and **Slope CAL**. Follow the sensor user-manual for each calibration step.

The user can change the sensor value corresponding to the 20mA output by selecting 20mA = [?]ppb. **\*NOTE\*** *The 20mA value span adjustment may only be equal to or lower than the upper range detection limit of the sensor.*

If an abnormal reading of the sensor is caused by improper calibration, users can restore the sensor to the factory calibration parameters by selecting **Restore Factory**.

### Assign a Specified Modbus Address for the sensor

For some special applications, users need to assign a new Modbus addresses to the sensor. For example, if you have two ST-525SS-T sensors, you will need to assign a different Modbus address to one of them.

1. Connect one of the two ST-525SS-T sensors to PowerPack Pro-5.
2. Navigate to the **sensor configuration screen** and select **Set Address**.
3. Set a new Modbus address and confirm (Modbus address must be between 1 to 240, and cannot be consistent with other sensors).
4. Address assignmenet is now complete. Power-off the PowerPack Pro-5 and connect two ST-525SS-T sensors .
5. Power-on the PowerPack Pro-5 and wait for the unit to complete a sensor scan.

### 7.4.2. Sensor Diagnosis

**Main Screen** ⇒ **Setup Menu** ⇒ **Probe Option** ⇒ **Select Sensor#** ⇒ **Diagnosis**

The PowerPack Pro-5 controller supports displaying the raw measurement data of the sensor in use. The information has no use for normal operation, but instead is used for sensor troubleshooting. This feature may be used for technical support when communicating with [service@pyxis-lab.com](mailto:service@pyxis-lab.com).

Name	Value	Name	Value
s365Dark	80	s420DI	3025
mAOut	20.00	t365	1413
CT365	38	t420	925
CS365	20	s420	3025
CT420	20		
CS420	43		
T365di	2935		
s365DI	215		
t420DI	925		

Figure. 19

### 7.4.3. Sensor Information

**Main Screen** ⇒ **Setup Menu** ⇒ **Probe Option** ⇒ **Select Sensor#** ⇒ **Information**

This screen contains the **PN** (part number ), **SN**(serial number), **Addr**(Modbus slave address) and **Ver**(software version) of the current channel sensor.

Information	
PN:56553	SN:24001
Addr:15	Ver:1.2r128

Exit

Figure. 20

## 8. Sensor Calibration with uPyxis

In addition to being able to calibrate using PowerPACK PRO-5, you can also choose to calibrate by connecting uPyxis.



Figure. 21 - Sensor Powered by PowerPACK Pro-5



Download and install the uPyxis app from Apple iStore or Google Play. Turn on the Bluetooth in the smart device (please do not pair your device Bluetooth to uPyxis, the app will do the pairing). Open the uPyxis app in the device. Swipe down to refresh the screen to scan the available Pyxis Bluetooth devices.

Tap the discovered sensor to connect to the sensor. The uPyxis app can identify the sensor type if multiple Pyxis sensors are discovered in the scan.

## 8.1. Dissolved Oxygen (DO) Calibration – ST-774

When connected, the uPyxis® 2.0 Mobile App will default to the Calibration screen. From the Calibration screen, you can perform calibrations by pressing on Zero Calibration, High Point Calibration, and 4–20mA Span.

**\*NOTE\*** Before calibrating, remove the ST-774 sensor from the water and wipe it with a damp cloth to remove debris and any fouling. If there is water on the membrane, dry it with a soft cloth taking care not to damage the membrane.

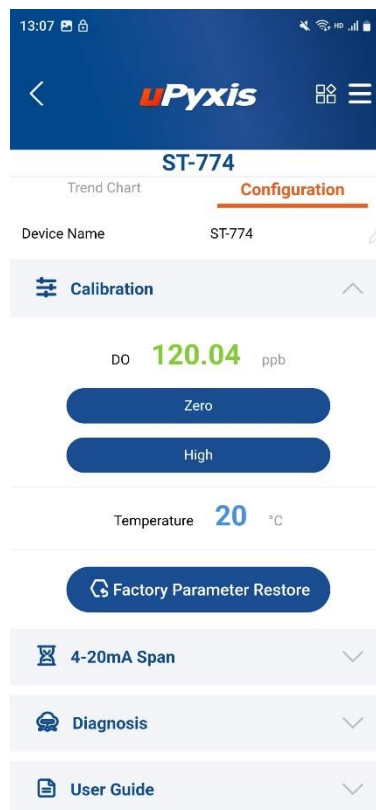

Figure. 22 - DO Calibration

### Zero Calibration Using Sulfite ZERO Calibration Kit (P/N 16019)

- 1) Unscrew the lid from the 10mL vial containing catalyzed sodium sulfite powder (P/N - SO3 VIAL).
- 2) Fill the vial with DI water to the 10mL mark.
- 3) Screw the lid on the vial and gently shake for 10 seconds.
- 4) Remove the Sulfite Zero Calibration Cap from packaging.

- 5) Unscrew the lid from the 10mL vial and pour the solution into the calibration cap



- 6) Rotate the calibration cap slowly over the front of the sensor. **\*NOTE\***: Any excess calibration fluid will flow out from the overflow port.

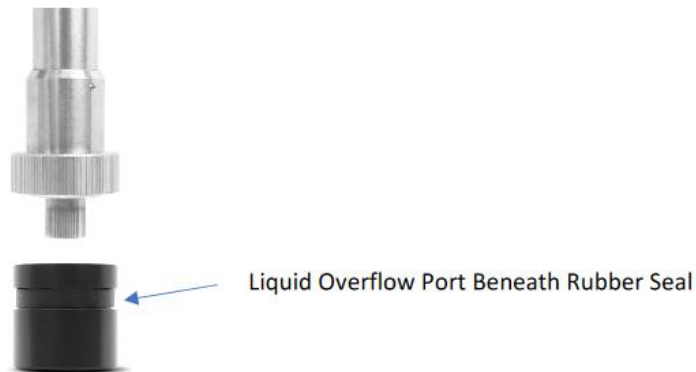

- 7) Place sensor in upright position on the Guardian PRO calibration shelf with the filled calibration cap at the bottom.

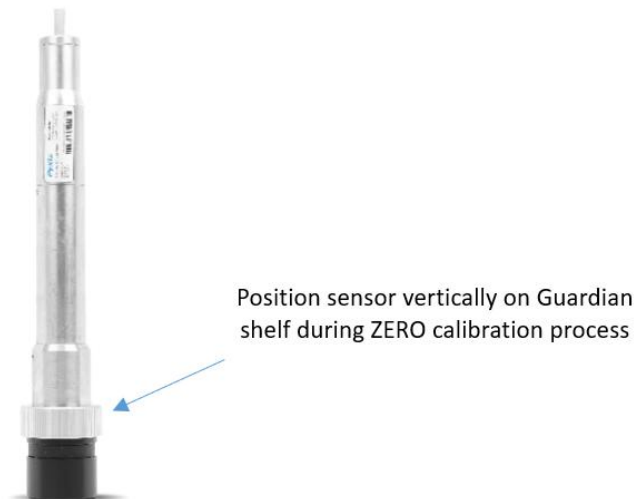

- 8) Click the Zero Calibration button on the screen and let the sensor remain on the calibration shelf in the standing position with sulfite solution for 12 hours for best results. This allows the catalyzed sulfite to completely react with any remaining dissolved oxygen in the cap until true zero.

- 9) After the 12-hour period, remove the calibration cap from the ST-774 sensor and rinse the sensor tip with DI water and insert sensor back into the ST-774 Flow Cell Assembly for service.



#### **Alternative Zero Calibration Using Pure Nitrogen Calibration Gas (99.999% or better)**

A depressurized nitrogen gas source can be connected to the sample cell through the ¼-inch OD stainless tubing for the zero-point calibration. The gas flow rate should be regulated between 2 and 10 liter per minute. **\*IMPORTANT NOTE\*** *Always ensure the stainless-steel compression fittings are very tight and always use stainless steel OD tubing.*

- 1) Connect pure Nitrogen gas cylinder output line to Guardian PRO sample inlet.
- 2) Place the sensor into the ST-774 Flow Cell Assembly.
- 2) Turn on a nitrogen gas flow.
- 3) Allow the gas flow through the Guardian PRO tubing to atmosphere until the temperature reading on the PowerPACK Pro-5 has been stabilized for at least 15 minutes.
- 4) Once the displayed oxygen and temperature values are stable, press Zero Calibration to perform a zero calibration.
- 5) If the calibration is successful, the interface will return a message "Calibration Succeeded". If the calibration fails, press Zero Calibration again and repeat.

---

**High Point/Slope Calibration Using Nitrogen Gas 99.9% with 0.1% Oxygen Calibration Gas**

A depressurized nitrogen with oxygen gas source can be connected to the sample cell through the ¼-inch OD stainless tubing for the high/slope calibration. The gas flow rate should be regulated between 2 and 10 liter per minute. **\*IMPORTANT NOTE\*** *Always ensure the stainless-steel compression fittings are very tight and always use stainless steel OD tubing.*

- 1) Carry out the zero-calibration using nitrogen gas first. See the Zero Calibration section.
- 2) Connect the Nitrogen (99.9%) with Oxygen (0.1%) gas cylinder output line to Guardian PRO sample inlet.
- 2) Place the sensor into the ST-774 Flow Cell Assembly.
- 3) Turn on a calibration gas (with known oxygen concentration) flow.
- 4) Allow the gas flow and the temperature to be stabilized for 15 minutes.
- 5) Once the displayed oxygen and temperature values are stable, press High Point Calibration
- 6) Enter the % Oxygen concentration of the calibration gas to perform a high point (slope) calibration.
- 7) If the calibration is successful, the interface will return a message "Calibration Succeeded". If the calibration fails, press High Point Calibration again and repeat

**ST-774 Service SWAP Program (P/N ST-774-SWAP)**

The ST-774 Service SWAP program is an alternative for users that do not want to conduct annual field calibration and maintenance of their ST-774. See overview of this service program below.

- (a) \$773 Per Year Factory Certified & Calibrated Sensor Only Exchange
- (b) Client Issues PO# to Pyxis Lab
- (c) Pyxis sends a factory certified new or reconditioned ST-774 sensor unit (without flow cell)
- (d) Client sends Pyxis their older ST-774 sensor unit (without flow cell)
- (e) Even exchange – eliminates client calibration and maintenance
- (f) Suggested annually
- (g) Contact [order@pyxis-lab.com](mailto:order@pyxis-lab.com) for details.

## 8.2. Sulfite (SO<sub>3</sub>) Calibration – ST-765SS-SO<sub>3</sub>

The measurement module of the ST-765SS-SO<sub>3</sub> sensor is thoroughly calibrated at the Pyxis Lab factory using an Argon saturated water sample containing a precise residual concentration of Sulfite. To field calibrate the ST-765SS-SO<sub>3</sub> sensor, the user can perform a single-point according to the requirements of the application.

Calibration of the ST-765SS-SO<sub>3</sub> sensor for Sulfite should be done with the sensor inline exposed to active flowing sample water. Use titration method, colorimeter or fluorometer (ie. Traditional Titration Method or Pyxis SP-800 / SP-910 Method SO<sub>2</sub>-LI Low Range Sulfite Test or Hach DR1300) to test the active (flowing) water sample in the flow tee assembly. Once you have tested and confirmed the Sulfite concentration value in the active (flowing) flow tee assembly, Tap SLOPE CALIBRATION and enter the test result value of the portable or laboratory colorimeter in Calibration Screen. **\*NOTE\*** For best results, the concentration of the Sulfite sample flow standard should be in the range of the sensor 4-20mA output setup for the actual application.

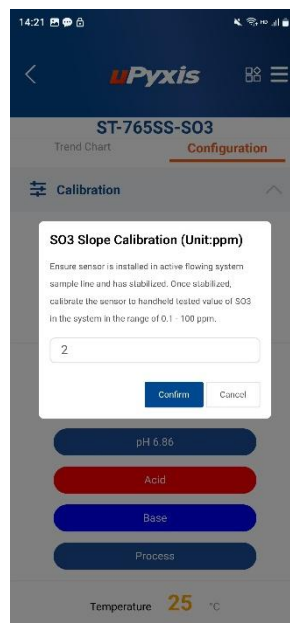

Figure. 23 - Slope Calibration

### Zero Calibration

**\*IMPORTANT NOTE\*** Under normal circumstances, the ZERO calibration of the ST-765 series sensor is not recommended or required, Pyxis Lab suggests Process Slope calibration only, unless otherwise directed via Pyxis Lab technical support team. Please refer to the Process Slope calibration procedure section for details.

If a zero calibration must be conducted, the Sulfite Zero calibration should be selected on the Sensor Calibration page. First put the sensor into the Zero-Oxidizer Standard Solution (Pyxis P/N 21022) or 100uS/cm Conductivity Standard is also acceptable for zero standard solution. After the sensor reading is stable for at least 10 minutes, click the “Zero cal” button to start the zero calibration. If the calibration is successful, the dialog box will display **"Calibration Successful"**.

### **Process Sulfite Slope Calibration**

While the sensor is exposed to an active sample flow of 100-500mL/min through the ST-765SS-SO3 sensor tee assembly, enter the measured Sulfite residual determined by the titration method or the Pyxis Low Range Sulfite Colorimeter Test (P/N 30604) using the SP-800 or SP-910. Users may also use a Sulfite Dropper Test Kit (P/N: TK35290-Z) based on application however the LDL of the dropper method is 2ppm and may be above what is actually maintained in the boiler feedwater.

Ensure that sensor reading has been stable for at least 10 minutes before calibration, click the “**Process Calibration**” button to start the process calibration. If the calibration is successful, the dialog box will display “**Calibration Successful**”.

***\*NOTE\*** Click the Recovery button in the calibration interface of the sensor to restore the factory calibration settings if a user error is made during calibration and other operations. This will restore the factory settings of the sensor through this function.*

### 8.3. pH Calibration – ST-765SS-SO3

The pH function is thoroughly calibrated at the Pyxis Lab factory prior to shipment. After removing the sensor and cleaning if necessary using Pyxis Probe Cleaner (P/N: SER-01) as outlined in Section 11.3 of this manual, check the sensor it with a pH standard buffer solution in a beaker. If the sensor value has shifted, then the user may choose from single-point, two-point or three-point calibration to re-calibrate the pH portion of the ST-765SS-SO3 sensor as desired. Pyxis Combo pH 4-7-10 Calibration Standard Kit (P/N:57007) or similar is suggested.

**\*NOTE\*** Click the Recovery button in the calibration interface of the sensor to restore the factory calibration settings if a user error is made during calibration and other operations. This will restore the factory settings of the sensor through this function.

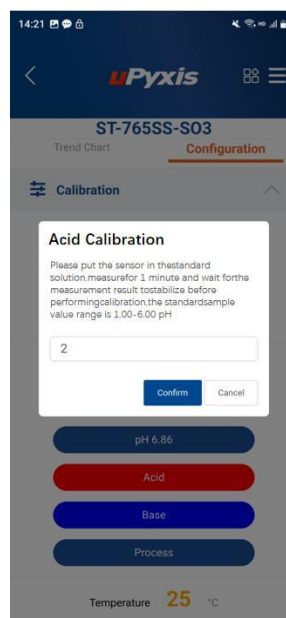

Figure. 24 - pH Calibration

A **Process Calibration** can be used if the pH calibration standard is not readily available for high, mid, and low calibration, or if there is a fixed deviation between the actual water sample and the true value after the user has done the calibration test. The pH process calibration is actually a correction (-0.5 to 0.5 pH units) made to the true pH value as measured by the sensor. Anything outside this range will require a formal calibration using pH calibration standard solution.

#### **Single Point pH Calibration:**

Remove the ST-765SS-SO3 sensor and rinse 3x with DI water ensuring there is no debris or fouling of the sensor electrode head. Submerge the sensor into a beaker with pH=7 buffer solution. Click "**pH7 calibration**". A dialog box will pop up to confirm whether to perform this operation, click "**OK**" if the calibration operation is confirmed, if the calibration is successful the dialog box will show "**Calibration Success**".

### **Two Point pH Calibration**

Remove the ST-765SS-SO3 sensor and rinse 3x with DI water ensuring there is no debris or fouling of the sensor electrode head. Submerge the sensor into a beaker with pH=7 buffer solution. Click "**pH7 calibration**". A dialog box will pop up to confirm whether to perform this operation, click "**OK**" if the calibration operation is confirmed, if the calibration is successful the dialog box will show "**Calibration Success**".

After pH7 is successfully calibrated, you can choose [Acid Calibration](#) or [Alkali Calibration](#) for the second calibration point. If you choose Acid Calibration, clean beaker 3x with deionized water. Fill the beaker with pH=4 buffer solution. Enter the value 4 in the calibration value dialog box, and click "**Acid Calibration**", then a dialog box will pop up to confirm whether to perform this operation. Click "**OK**" if the calibration operation is confirmed and the dialog box will show "**Calibration Successful**" if the calibration is successful. Similarly a pH=10 buffer solution can be selected for the second point calibration if desired. Figure.

### **Three Point pH Calibration:**

Remove the ST-765SS-SO3 sensor and rinse 3x with DI water ensuring there is no debris or fouling of the sensor electrode head. Submerge the sensor into a beaker with pH=7 buffer solution. Click "**pH7 calibration**". A dialog box will pop up to confirm whether to perform this operation, click "**OK**" if the calibration operation is confirmed, if the calibration is successful the dialog box will show "**Calibration Success**".

After pH7 is successfully calibrated, you can choose [Acid Calibration](#) or [Alkali Calibration](#) for the second calibration point. If you choose Acid Calibration, rinse the beaker 3x with deionized water. Fill the beaker with pH=4 buffer solution. Enter the value 4 in the calibration value dialog box, and click "**Acid Calibration**", then a dialog box will pop up to confirm whether to perform this operation. Click "**OK**" if the calibration operation is confirmed and the dialog box will show "**Calibration Successful**" if the calibration is successful.

After successful Acid Calibration, select pH=10 for Alkali Calibration. Rinse the beaker 3x with deionized water. Fill the beaker with pH=10 buffer solution. Enter the value 10 in the calibration value dialog box, and click "**Alkali Calibration**", then a dialog box will pop up to confirm whether to perform this operation. Click "**OK**" if the calibration operation is confirmed and the dialog box will show "**Calibration Successful**" if the calibration is successful. The three-point calibration is completed.

### 8.4. ORP Calibration – ST-765SS-SO3

Close the water inlet valve and remove the sensor and rinse 3x with DI water ensuring there is no debris or fouling of the sensor electrode head. If the sensor is fouled, clean it using the Pyxis Probe Cleaning Kit (P/N: SER-01) as outlined in Section 11.3 of this user manual. Once clean submerge the sensor into a beaker filled with Pyxis ORP-200 Calibration Standard Solution (P/N: 57020) or similar. Enter the known concentration of the ORP standard solution in the calibration screen and click **“Calibrate”**. A dialog box will pop up to confirm whether to perform this operation. If the calibration operation is confirmed, click **“OK”**. If the calibration is successful, the dialog box will display **“Calibration Successful”**.

**\*NOTE\*** Click the Recovery button in the calibration interface of the sensor to restore the factory calibration settings if a user error is made during calibration and other operations. This will restore the factory settings of the sensor through this function.



Figure. 25 - ORP Calibration

## 8.5. Fluorescein (Tracer) Calibration – ST-525SS-T

### Single Point (In-Situ) Fluorescein Calibration

Remove and clean the ST-525SS-T series sensor using Pyxis Probe Cleaner (P/N: SER-01) as outlined in Section 11.3 of this manual.

After adequate sensor cleaning has been confirmed, place the sensor back into the sample flow stream and allow it to stabilize. Users can conduct an ‘in-situ’ calibration of the sensor by confirming the known value of fluorescein through a handheld test of the sample water using Pyxis SP-380 or SP-910. Once the sensor has stabilized, enter the actual flow sample fluorescein value into the uPyxis interface, then click “**High Calibration**”, wait for the calibration completion prompt to pop up, which means the calibration is successful.

**\*IMPORTANT NOTE\*** *If the sensor is dirty, it must be removed for proper optical channel cleaning with the Pyxis Probe Cleaning Solution (P/N SER-01) prior to conducting sensor calibration.*

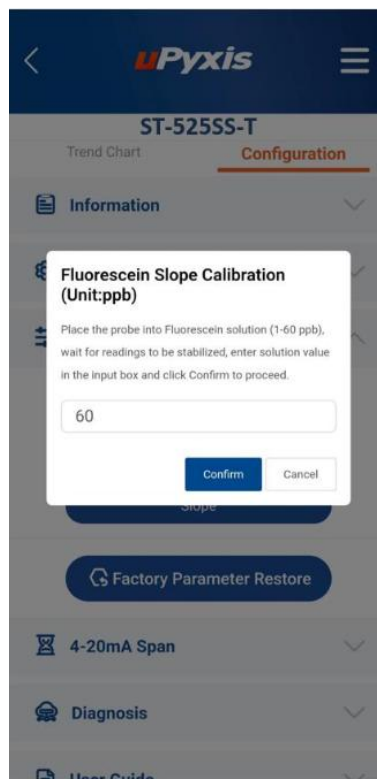

Figure. 26 Fluorescein Calibration

**\*IMPORTANT NOTE\***: *For best results, the ST-525SS-T sensor should be calibrated in a completely light-proof environment by covering the beaker with a towel.*

**Two-Point (Beaker) Fluorescein Calibration**

The two-point Fluorescein calibration for the ST-525SS-T series requires the following Pyxis calibration standards for adequate Zero and Slope calibration.

Calibration Point	Item Name	Pyxis P/N
Zero Calibration	DI Water	NA
Slope Option #1	10ppb Fluorescein Std. Solution	FLUO-10
Slope Option #2	20ppb Fluorescein Std. Solution	FLUO-20

After cleaning the sensor, place the sensor into a beaker containing deionized (DI) water. Please allow sufficient time (a few minutes) for the sensor to stabilize before performing the calibration, then tap **Zero Calibration**.

After completing the zero calibration, place the sensor into FLUO-10 or FLUO-20 calibration standard solution (based on application need) , enter the standard solution value in the interface, then click **“High Calibration”**, wait for the calibration completion prompt to pop up, which means the calibration is successful.

**\*IMPORTANT NOTE\***: For best results, the ST-525SS-T sensor should be calibrated in a completely light-proof environment by covering the beaker with a towel.

**8.6. Conductivity (TDS) Calibration – ST-724**

The conductivity sensor only needs to be calibrated once, put the sensor into the standard solution with known standard solution value, enter the standard solution value in the interface, then click **“Calibration”**, wait for the calibration completion prompt to pop up, which means the calibration is successful.

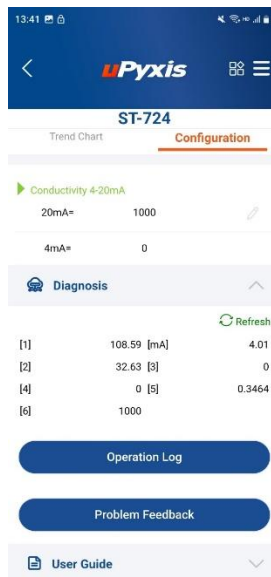

Figure. 27 Conductivity Calibration

## 9. Replacing ST-765SS-SO3 pH, ORP and Sulfite Electrode Head

The EH-765 electrode head (P/N: 53061) of the ST-765SS-SO3 sensor can be replaced when the original electrode heads have reached the end of their working life. The typical working life of the electrode can be as long as 2-years under normal operating conditions. Please refer to the following steps to replace the electrode head of your sensor.

1. Isolate the sensor by turning off sample flow. Remove and make sure there is no water on the sensor.
2. Hold the sensor main body with one hand and use the other hand to twist the locking ring counterclockwise until the front end of the black electrode is completely unscrewed, as shown in Figure 28-2. ***\*NOTE\* The sensor electrode head should be oriented towards the ground to avoid residual water getting into the sensor.***
3. Thoroughly wipe the electrode head with a dust-free cloth or paper-towel then pull out the electrode head as shown in Figure 28-3.
4. Gently loosen the electrode plug connector and remove the electrode head, as show in Figure 28-4.
5. To install the new electrode head, please use the mounting hook to securely plug in the wiring connector, as shown in Figure 28-5. ***\*NOTE\* Before connecting the electrode head, please make sure that the new electrode head gasket is properly installed at the base of the electrode head thread to ensure a watertight seal, as shown in Figure 28-5.***
6. Then reconnect, insert the new electrode head into the main sensor housing and ensure that the two alignment protrusions on the electrode head are aligned with the notches in the sensor body housing, as shown in Figure 28-6. Then twist the lock ring of sensor in a clockwise direction until the threads of the electrode head completely enter the sensor housing as shown in Figure 28-1. ***\*NOTE\* Be sure to return your sensor operation to Flow Interlock Auto Mode***



Figure. 28 - Replacing EH-765 pH, ORP and Sulfite Electrode Head

## 10. Replacing ST-774 Dissolved Oxygen Cartridge Assembly (DCC-2)

Remove the ST-774 dissolved oxygen sensor from the flow cell assembly. Slowly unscrew the DCC-2 (P/N: 53716) Membrane Cap from the ST-774 sensor. Gently clean the sensor eye and install the new replacement DCC-2 Membrane Cap onto the ST-774 sensor. Your sensor is now ready for service for another year of operation. **\*NOTE\*** Replacement of this cartridge is suggested annually.



## 11. Sensor Cleaning with Pyxis Probe Cleaning Kit

In the event of heavy inorganic deposition of any Pyxis sensors installed on the Guardian PRO Boiler Feedwater Analyzer Series, users may conduct an off line chemical cleaning using the Pyxis Probe Cleaning Kit (P/N: SER-01). Remove the sensor and inspect the internal components of the stainless steel flow cell. If necessary flush the flow cell thoroughly with clean water until adequately clean. Fill the provided beaker and soak the lower half of the sensor in 100 mL of Pyxis Probe Cleaning Solution for 10-15 minutes. Gently wipe the sensor electrode head with the provided Q-tips. If an optical sensor (i.e. ST-525S-T), use the provided pipe cleaning brushes to gently brush the inner surfaces of the optical channel itself. If the surfaces are not entirely clean, continue to soak the sensor for an additional time until clean. Rinse the sensor with distilled water. Pyxis Lab Probe Cleaning Kit can be purchased at our online Estore/Catalog at <https://www.pyxis-lab.com/product/inline-sensor-cleaning-kit/>



### Contact Pyxis Lab

21242 Spell Circle

Tomball, TX. 77375

[service@pyxis-lab.com](mailto:service@pyxis-lab.com) for technical service and support

[order@pyxis-lab.com](mailto:order@pyxis-lab.com) for order and pricing inquiries

1-866-203-8397 Phone USA for all needs

Office Hours 7AM – 5PM Central Time USA