

# ARGAL

## USER MANUAL ROUTE TMR G2 (sealless)

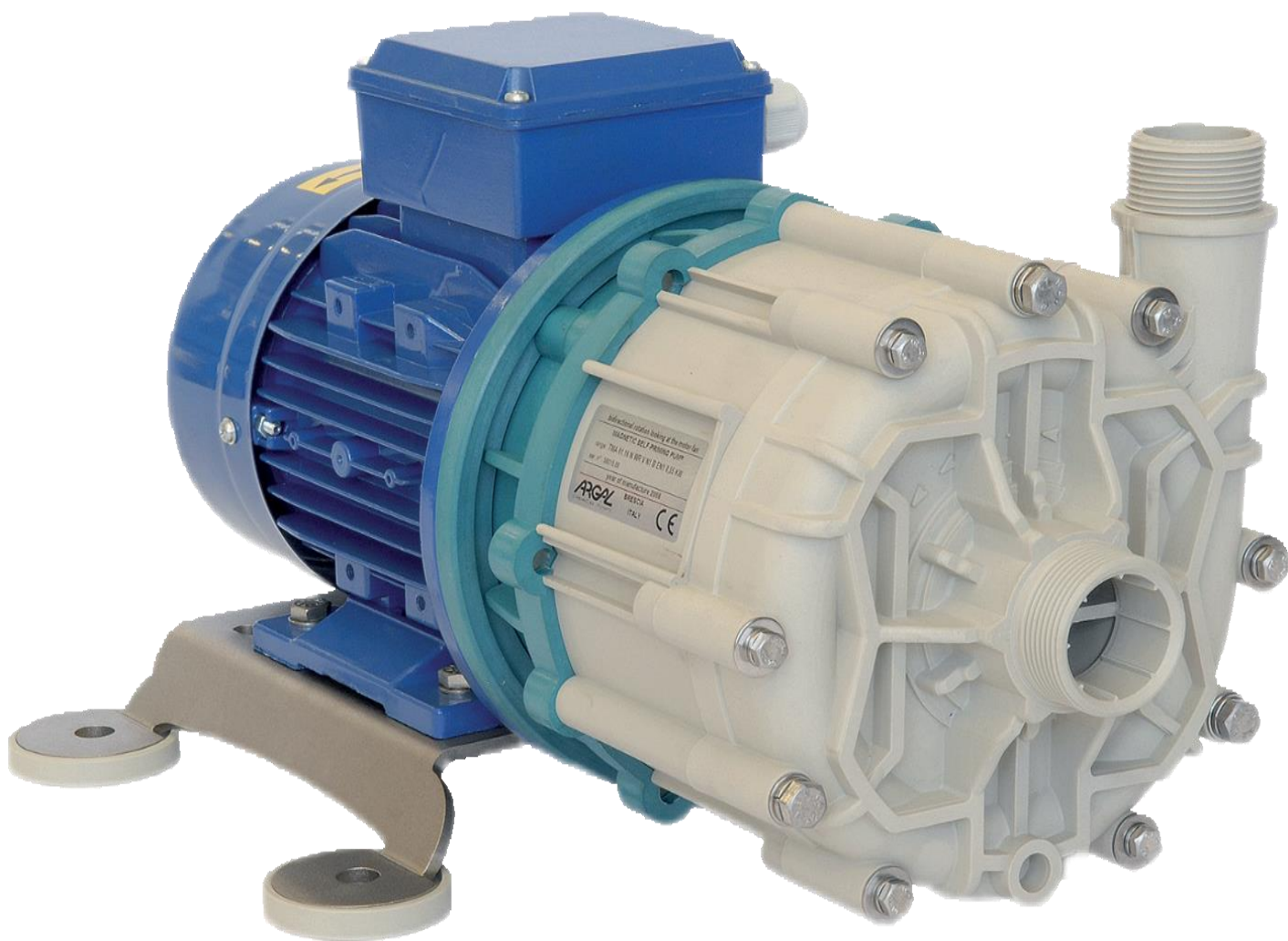

**EAC CE**

DEALER

For maintenance:  
date of commissioning





References: position/system reference

Service:

# INDEX

<b>3 IDENTIFICATION CODE</b>
<b>4 DISASSEMBLING SEQUENCE</b>
<b>5 HYDRAULIC PARTS LEGEND</b>
<b>6 MOTOR PARTS LEGEND</b>
<b>7 GENERAL NOTES</b>
<b>8 OPERATING PRINCIPLE</b>
<b>8 MOTOR</b>
<b>9 DRY RUNNING SURVEY</b>
<b>9 INSTRUCTIONS ON INSTALLATION AND USE</b>
9 STORAGE INSTRUCTIONS
9 TRANSPORT
9 INSTALLATION
10 START-UP
11 USE
11 SHUTDOWN
<b>11 MAINTENANCE</b>
11 DISMANTLING
12 INSPECTION
13 ASSEMBLY
<b>14 SAFETY RISKS</b>
14 INSTALLATION AND START-UP PERSONNEL
14 MAINTENANCE AND OPERATIONAL PERSONNEL
14 PERSONNEL RESPONSIBLE FOR REPAIRS
15 WASTE DISPOSAL
15 IMPROPER USE
<b>16 OPERATING FAULTS AND POSSIBLE CAUSES</b>
<b>17 TECHNICAL DATA</b>
<b>19 POSITIONING DRIVE MAGNET ASSEMBLY</b>
<b>20 GENERAL CONDITIONS OF SALE</b>
<b>22 WARRANTY FORM</b>
<b>24 MANUFACTURER DATA</b>
<b>25 ATTACHMENTS</b>
- DECLARATION OF CONFORMITY (MACHINERY DIRECTIVE 2006/42/EC)
- MOTOR USE MANUAL

# IDENTIFICATION CODE

Pump data				Motor data			
range	model	execution (materials)		internal structure	rpm	power	phase
TMR	<input type="checkbox"/> 06.10	<input type="checkbox"/> WR (polipropilene PP)		<input type="checkbox"/> R1 (C/Al <sub>2</sub> O <sub>3</sub> )	<input type="checkbox"/> 1450	<input type="checkbox"/> 0.18 kW	<input type="checkbox"/> 1 (monofase)
	<input type="checkbox"/> 10.10	<input type="checkbox"/> GF (etilene-cloro trifluoro etilene E-CTFE)		<input type="checkbox"/> X1 (SiC/Al <sub>2</sub> O <sub>3</sub> )	<input type="checkbox"/> 2900	<input type="checkbox"/> 0.25 kW	<input type="checkbox"/> 3 (trifase)
	<input type="checkbox"/> 10.15	<input type="checkbox"/> GX (etilene-cloro trifluoro etilene E-CTFE) 		<input type="checkbox"/> N1 (CFF+PTFE/Al <sub>2</sub> O <sub>3</sub> )	<input type="checkbox"/> 1740	<input type="checkbox"/> 0.37 kW	
	<input type="checkbox"/> 16.15			<input type="checkbox"/> R2 (C/SiC) 	<input type="checkbox"/> 3480	<input type="checkbox"/> 0.55 kW	voltage/EEx
	<input type="checkbox"/> 16.20	version	connections				<input type="checkbox"/> 0 (senza motore)
	<input type="checkbox"/> 02.30	<input type="checkbox"/> N normale	<input type="checkbox"/> B (BSP threaded)		<input type="checkbox"/> X2 (SiC/SiC)		<input type="checkbox"/> N (tensione STD)
	<input type="checkbox"/> 07.11	<input type="checkbox"/> P potenziata	<input type="checkbox"/> N (NPT threaded)		<input type="checkbox"/> N2 (CFF+PTFE/Si ) 	standard	<input type="checkbox"/> S (tensione speciale)
	<input type="checkbox"/> 07.14	<input type="checkbox"/> S sovrapoten.	<input type="checkbox"/> Z (ISO ANSI JIS flanged)			<input type="checkbox"/> E (IEC)	<input type="checkbox"/> N (NEMA)
	<input type="checkbox"/> 11.15					<input type="checkbox"/> N (NEMA)	<input type="checkbox"/> E (EEX) 
	<input type="checkbox"/> 11.23	O-ring	outside structure				<input type="checkbox"/> 3 kW
	<input type="checkbox"/> 17.15	<input type="checkbox"/> V (FPM)	<input type="checkbox"/> Integral				<input type="checkbox"/> 4 kW
	<input type="checkbox"/> 03.35	<input type="checkbox"/> E (EPDM)	<input type="checkbox"/> Armoured				
		<input type="checkbox"/> K (FFKM)					

 : choice for ATEX versions

Each pump is supplied with the serial and model abbreviation and the serial number on the rating plate, which is riveted onto the support side. Check these data upon receiving the goods. Any discrepancy between the order and the delivery must be communicated immediately.

In order to be able to trace data and information, the abbreviation, model and serial number of the pump must be quoted in all correspondence.

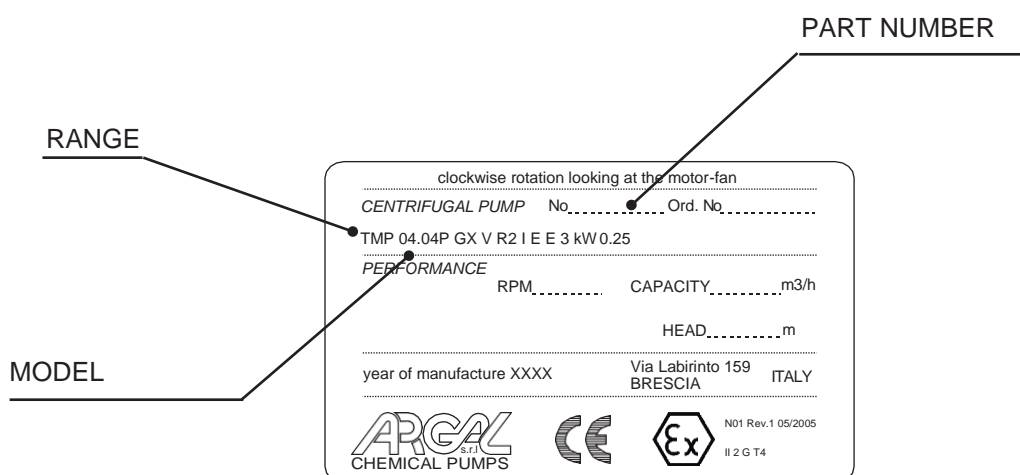

# DISASSEMBLING SEQUENCE

## TOOLS

Spanner No 13

## EXECUTION NOTES

- To facilitate the pump disassembling operations, first disassembly the HYDRAULIC PARTS from the MOTOR PARTS
- unscrew the connections (POS.1)
- warning! The disassembly operations of parts magnetically connected involve great opposed forces: keep the MOTOR PARTS fixed on floor during the removing of the HYDRAULIC PARTS.

## WARNING

The interventions must be performed under supervision of qualified personnel.

Before starting remember:

- cut off the power supply from the motor and disconnect the electrical wiring; pull the wires out from the terminal box and isolate their extremities accordingly
- close the suction and discharge valves; open the drain valve
- use appropriate gloves, protective glasses and acid proof-clothing when disconnecting and washing the pump
- disconnect hydraulic connections: leave enough time for the residual liquid to exit the pump casing and atmospheric air to fill the empty volume
- wash the pump before starting maintenance operations
- do not scatter the washing liquid in the environment
- before attempting to dismantle the pump ensure that its motor is disconnected and that it may not be started accidentally
- before the inspection, check that you have spare O-rings ready to hand for re-installing at the end of operations
- warning! Operations near the magnets attract the tools. Proceed with caution to avoid damages.

For further details see paragraph 9.1 "Disassembling"

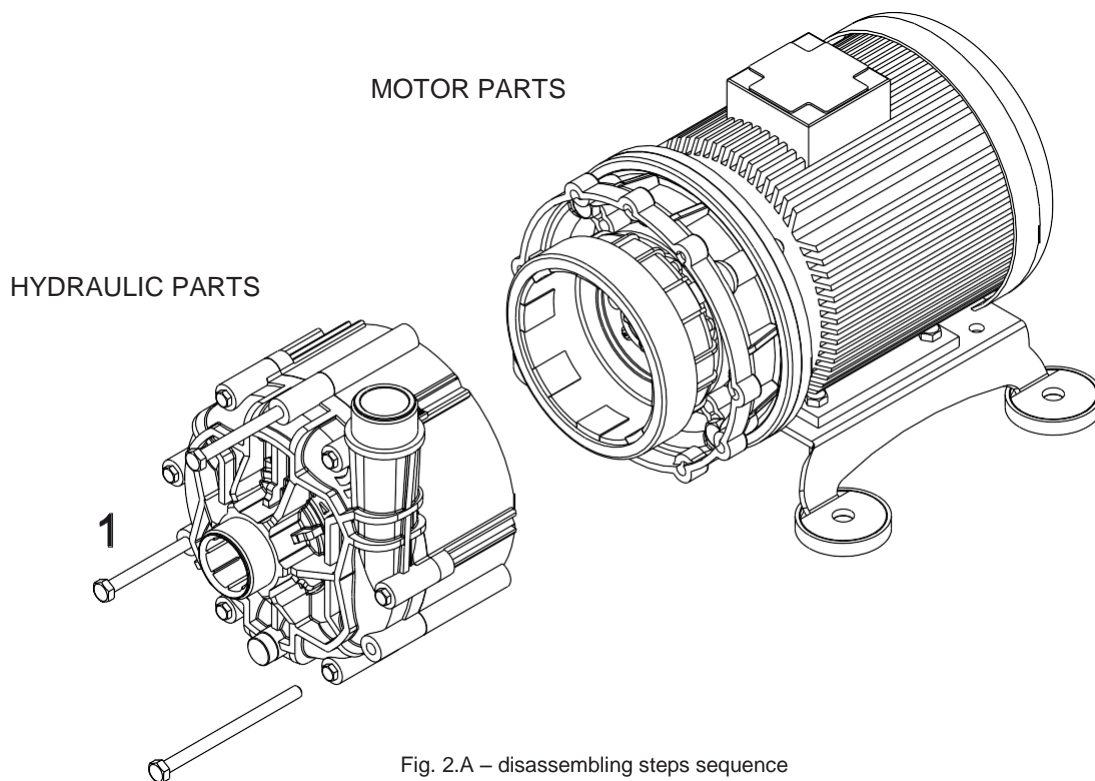

Fig. 2.A – disassembling steps sequence

note	ref	pos.	Part name	Q.ty	Disassembling steps sequence										Spare stock for working years		
					1	2	3	4	5	6	7	8	9	10	2	5	
	1	910.1	Connection volute casing/strainer	3	•												

# HYDRAULIC PARTS LEGEND

## TOOLS

Spanner No 10

## EXECUTION NOTES

- disassembly keeping the pump in vertical position (suction on top)
- unscrew the connections (POS.2)

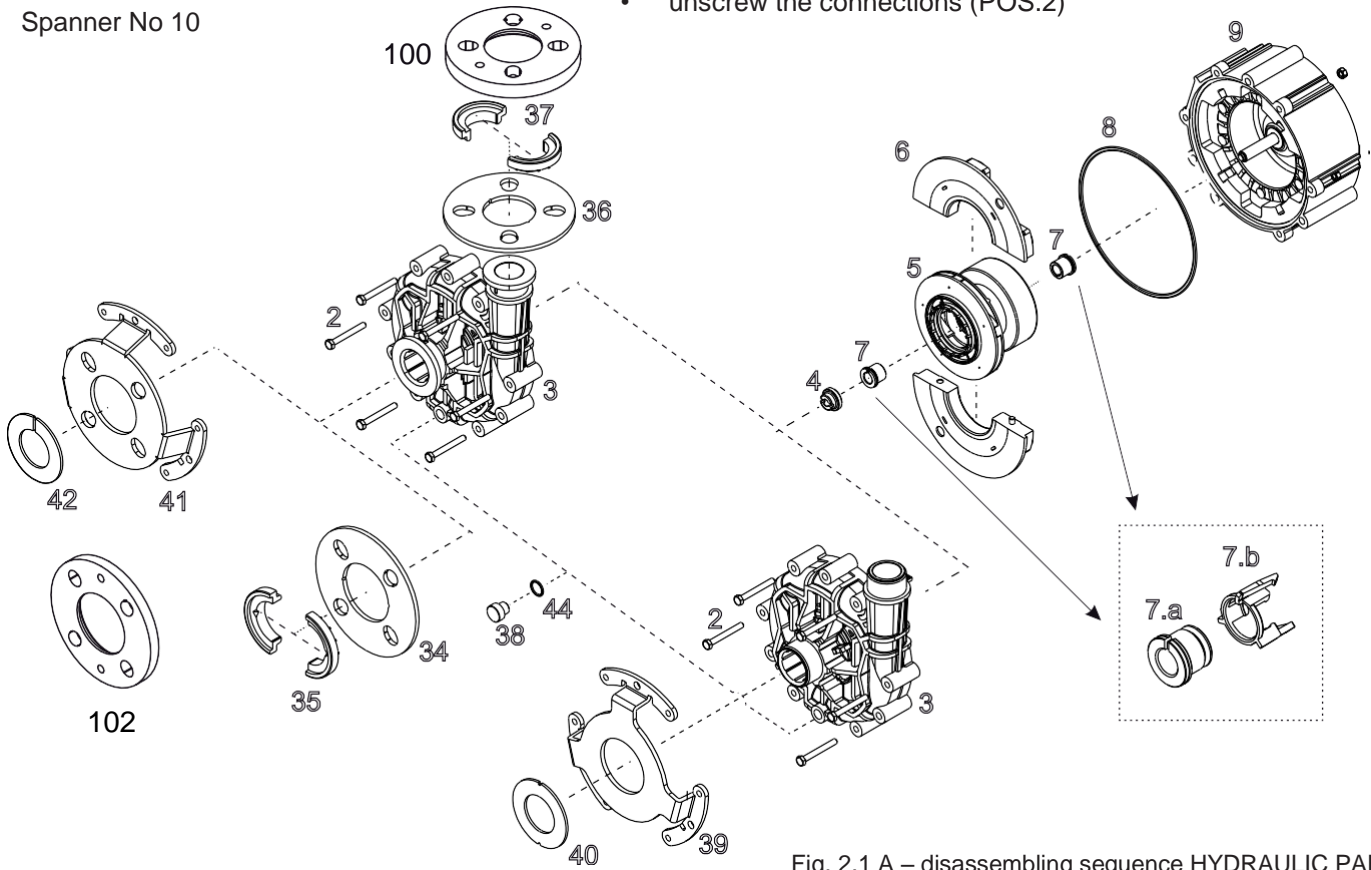

Fig. 2.1 A – disassembling sequence HYDRAULIC PARTS

note	ref	pos.	Part name	Q.ty	Disassembling steps sequence										Spare stock for working years		
					1	2	3	4	5	6	7	8	9	10	2	5	
	2	910.2	Connection volute casing/rear casing	6		•											
	3	102	VOLUTE CAGING	1			•										1
	4	331	FRONT THRUST BEARING	1				•									1
	5	233	IMPELLER	1					•								1
	6	134	CENTER DISC	2						•							
	7	545	GUIDE BUSHING WITH BUSHING FASTENER	2							•						2
	7.a	545	GUIDE BUSHING	2													
	7.b	222	BUSHING FASTENER	2													
	8	412	OR VOLUTE CASING	1								•					1
	9	162	REAR CASING	1									•				1
	34	722.1	INLET FLANGE	1	•												
	35	727.1	INLET FLANGE-ADAPTOR	2	•												
	36	722.2	OUTLET FLANGE	1	•												
	37	727.2	OUTLET FLANGE-ADAPTOR	2	•												
	38	912	DRAIN PLUG (optional)	1	•												
	39	195.1	ARMOURED (connect. B – N) (optional)	1			•										
	40	922	LOCK NUT (optional)	1		•											
	41	195.2	ARMOURED (connect. Y – Z) (optional)	1			•										
	42	932.1	SEEGER RING (optional)	1		•											
	44	412.1	OR DRAIN PLUG (optional)	1		•											
	100	722.3	OUTLET FLANGE FF	1		•											
	102	722.4	INLET FLANGE FF	1		•											

# MOTOR PARTS LEGEND

## TOOLS

- Screw driver
- Type Phillipsq
- punch f < 4 mm

## NOTE OPERATIVE

- Unscrew the connections (POS.10)
- Remove the collar from the drive magnet assembly using the punch (see paragraph 9.1)

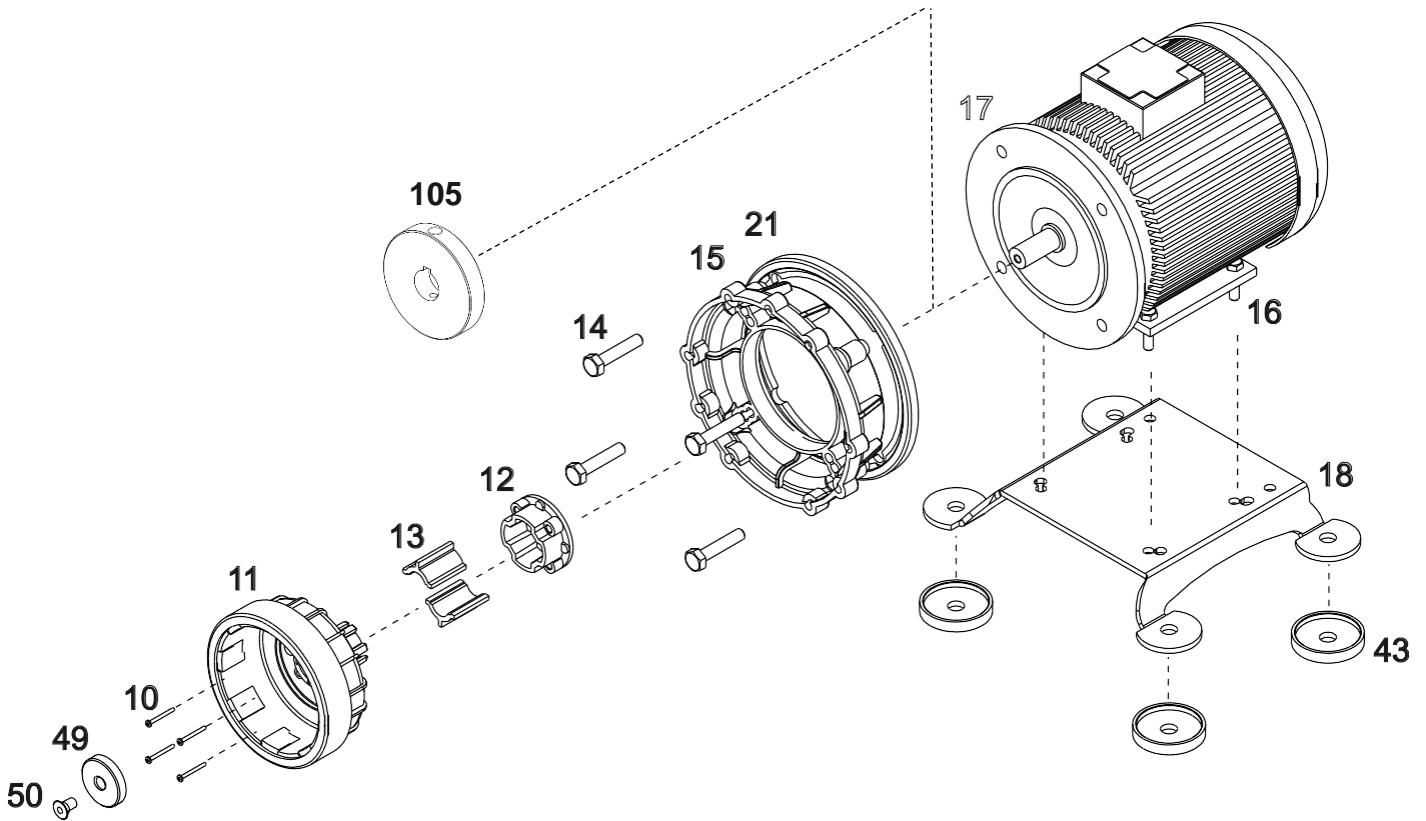

Fig. 2.2 A – disassembling sequence MOTOR PARTS

note	ref	pos.	Part name	Q.ty	Disassembling steps sequence										Spare stock for working years		
					1	2	3	4	5	6	7	8	9	10	2	5	
	10	910.3	Connection drive magnet assembly / electric motor	4			•										
	11	855	DRIVE MAGNET ASSEMBLY	1				•									
	12	518	COLLAR ( drive magnet assembly )	1					•								1
	13*	523	SOCKET	2													
	14	910.4	Connection strainer / electric motor	4						•							
	15	807	BRACKET	1							•						
	16	910.5	Connection electric motor / baseplate	4								•					
	17	800	ELECTRIC MOTOR	1									•				
	18	890	BASEPLATE (optional)	1										•			
	21	334	PACKING RING	1								•					
	43	185	DISCO BASE (optional)	4													
	49	934	SAFETY WASHER	1		•											
	50	910.6	Connection safety washer / motor shaft	1		•											
	105**		Fly-Wheel	1									•				

(\*) with 3-4 kW motor power , the sockets are replaced by a space ring

(\*\*) valid only for 3-4 kW motor power

## GENERAL NOTES

"TRM" pumps are designed and built for the transfer of liquid chemical products having a specific weight, viscosity, temperature and stability of state appropriate for use with centrifugal pumps in a fixed installation, from a tank at a lower level to a tank or a pipe to a higher level. The characteristics of the liquid (pressure, temperature, chemical reactivity, specific weight, viscosity, vapour tension) and the ambient atmosphere must be compatible with the characteristics of the pump and are defined upon ordering.

The pump's performance (capacity, head, rpm) is defined upon ordering and specified on the identification plate.

"TMR" and pumps are centrifugal, horizontal, single stage, coupled to a non-synchronous electric motor via a magnetic coupling, with axial inlet and radial outlet for connection to the hydraulic system. They are foot-mounted for floorfixing.

"TMR" pumps are not self priming.

R1-R2 execution "TMR" pumps can run dry.

The liquid to be pumped must be clean for the R1-2 execution, the X1-2 execution may contain solid (% , dimension and solid part hardness must be agreed during the offer).

Clockwise rotation seen from the motor side.

Make sure that the chemical and physical characteristics of the liquid have been carefully evaluated for pump suitability.

Verify the compatibility with the physical-chemical characteristics of the liquid.

The specific weight that can be pumped at 25 °C (liquid and environment) referred to max flow (50 e 60 Hz) depend upon the type of construction:

standard construction N (stamped on the rating plate)	1,05	kg/dm <sup>3</sup>
powered construction P (stamped on the rating plate)	1,35	kg/dm <sup>3</sup>
strong-powered construction S (stamped on the rating plate)	1,80	kg/dm <sup>3</sup>

The specific weight that can be pumped at 70°C is 10% less than that at 25°C.

The level of cinematic viscosity must not exceed 30 cSt so as not to significantly modify the pump's performance. Higher values up to a maximum of 100 cSt are possible provided that the pump is equipped with suitable impeller to be defined upon ordering.

The maximum continuous working temperature referred to water depends on the choice of materials (specified on the identification plate):

80 °C (176 °F)	execution WR
110 °C (230 °F)	execution GF

The ambient temperature interval is related to the choice of materials (specified on the identification plate):

0 - +40°C (14,104 °F)	execution WR
-20 - +40°C (-4 ,104 °F)	execution GF

The maximum pressure the pump may be subjected to is 1.5 times the head value developed with the outlet closed.

The vapour pressure value of the liquid to be pumped must exceed (by at least 1m w.c) to the difference between the absolute total head (suction side pressure added to the positive suction head, or subtracted by the suction lift) and the pressure drops in the suction side piping (including the inlet NPSHr drops shown on the specific tables).

The pump does not include any non return valve nor any liquid flow control or motor stop device.

## OPERATING PRINCIPLE

HYDRAULICALLY alike to all centrifugal pumps, it is equipped with a blade-type impeller rotating within a fixed housing. It has a tangential outlet (or radial with an internal deflector) and, by creating a depression in the center, it allows the liquid to flow from the central suction side. Then, flowing through the impeller's blades, the fluid acquires energy and is conveyed towards the outlet.

MECHANICALLY different from the traditional centrifugal pumps in the impeller motion drive thanks to the magnetic field created between the primary outer magnet and the inner magnet (not visible because housed inside the impeller hub). The magnetic field crosses the plastic parts and the liquid, and firmly couples the two magnet assemblies. When the motor causes the outer magnet to rotate together with its housing, the inner magnet assembly is dragged at the same speed. As a result the impeller, which is integral to it, is maintained in rotation.

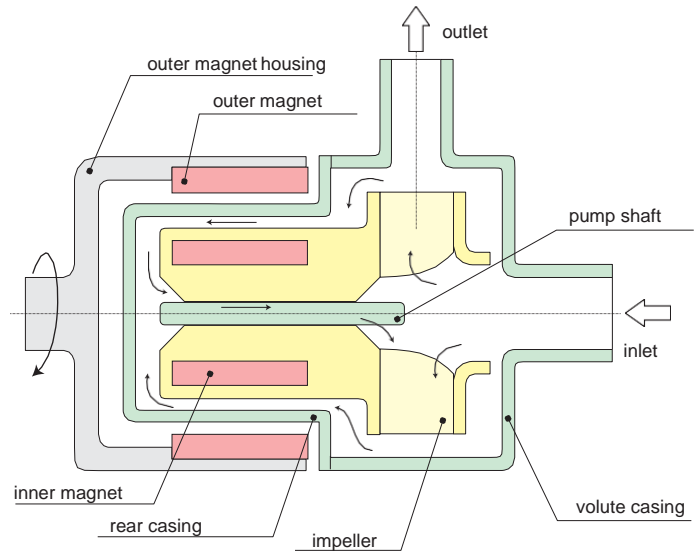

The SHAFT, totally within the housing, is not involved in the transmission of rotary motion; its only function is to act as a centering guide and support for the impeller. To this end the components are designed so that a spontaneous cooling circuit (due to a simple effect of pressure) is established to cool the surfaces subject to friction. Periodic inspections prevent the build-up of sediments between the shafts and the guide bushes significantly lengthening their working life.

## MOTOR

### Electrical connections

The electrical connection to the motor terminal determines the direction of rotation of the motor and can be verified by looking at the cooling fan at the rear of the motor ( for the Argal pump this has to rotate clockwise looking at the front end).

With single phase motors the direction of rotation may be reversed by changing the position of the connection plates(fig.1)

With three-phase motors the direction of rotation may be changed by swapping any two of the three conductors independently of the type of connection to the windings(fig.2)

The windings of three-phase motors ( e.g. with (a) 230-400 V; (b) 400-600 V) require a delta-connection for lower voltage ( 230 volts for a ; 400 volts for b)(fig.3)

They require a star-connection for higher voltage (400 volts for a; 690 volts for b)(fig.4)

Star/Delta starting is used when the motor power is above 7.5 kW (10 HP ) only in case of frequent starts and short running times, but always when the motor power is above 15kW (20 HP ). All this is also to safeguard the structure of the pump.

### Protection level

The initials IP are followed by two numbers :

The first number indicates the level of protection against penetration of solid objects and in particular :

- 4 for solids whose dimension is greater than 1mm
- 5 for dust (eventual internal deposits will not harm operation)
- 6 for dust (no penetration)

The second number indicates the protection against the penetration of liquids. In particular:

- 4 for water sprays from all directions
- 5 for jets of water from all directions
- 6 for tidal and sea waves.

According to the IP protection indicated on the identification plate of the motor and to the environmental conditions, arrange for opportune extra protections allowing in any case correct ventilation and rapid drainage of rainwater.

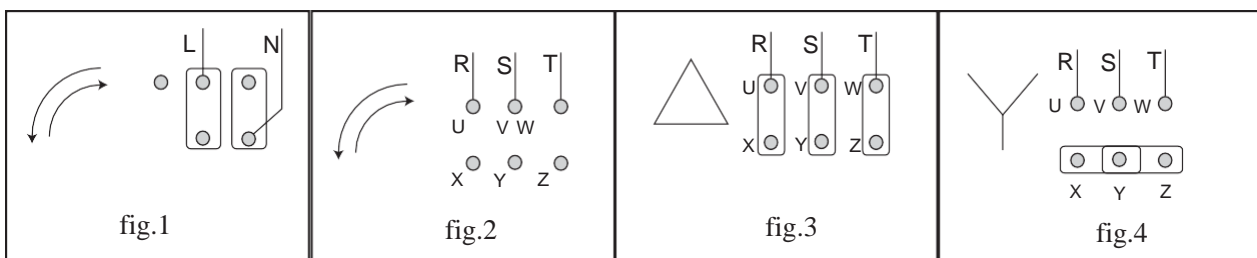



## DRY RUNNING SURVEY

Though the pump can run dry (execution R1-R2) , it is therefore suitable to safeguard the pump and the plant to use:

- pressure switch;
- fluxmeter;
- control devices for the motor power absorption.

## INSTRUCTIONS ON INSTALLATION AND USE

### TRANSPORT

- cover the hydraulic connections
- when lifting the unit do not exert force on the plastic fittings
- lay the pump on its base or fixing plate during transport
- if the road is particularly rough, protect the pump by means of adequate shock absorbing supports
- bumps and shocks may damage important working parts vital for safety and functionality of the machine

### STORAGE INSTRUCTIONS

- When it is necessary to store the pump before installation don't remove it from the original packaging.
- The packaged pump must be stored lifted from ground level, the ambient must be close, clean and dry.
- If at the receipt of the pump package seems damaged it is necessary to free the pump in order to check its integrity and to store a new package.
- The place where the pump is stored must be closed with an ambient temperature not lower than  $-5^{\circ}\text{C}$  and not higher than  $40^{\circ}\text{C}$ , the air humidity rate not higher than 80%, the package pump mustn't received shock, vibrations and loads rising above.
- If the storing period is higher than 6 months, before installation check the condition of the grease in the support, eventually provide to restore it.

### INSTALLATION

clean the plant before connecting the pump

make sure that no foreign bodies are left in the pump. Remove safety caps on the hydraulic connections.

follow the instructions indicated in the following diagram:

- 1) Suction head varies according to flow in order to prevent windage (min. 0.5 m, max. 15% of pump head)
- 2) YES: expansion joint (indispensable with long pipes or hot liquids) and/or anti-vibration facility during discharge and suction; anchored near to pump
- 3) YES: attachment for gauge or safety pressure switch
- 4) YES: check valve (especially for long vertical or horizontal pipes; compulsory with parallel pumps).
- 5) YES: adjusting gate valve on outlet
- 6) speed of delivered fluid: 3.5 m/s max. .
- 7) NO: elbow joints (and other parts) on the pump (discharge and suction lines)
- 8) YES: drainage channel around base
- 9) Fix the pump by the fixing holes provided: the supports must be level
- 10) YES: pipe discharge (completely sealed), discharge valve shut during normal operations
- 11) YES: pipe fixing parts
- 12) YES: discharge collection well (does not leak)
- 13) Fluid speed suction: 2.5 m/s
- 14) NO: air pockets: the circuit must be short and straight
- 15) With positive head: tilt of piping towards pump
- 16) With negative suction lift: tilt of piping towards suction tank
- 17) YES: check valve (with negative suction lift)
- 18) YES: gate valve (may also be near pump in the case of long piping)
- 19) YES: strainer (3-5 mm mesh)
- 20) YES: strainer (3-5 mm mesh)
- 21) Suction head, 3 m max.
- 22) Immersion depth: 0.3 m min.
- 23) YES: overcoming obstacles at lower depths.

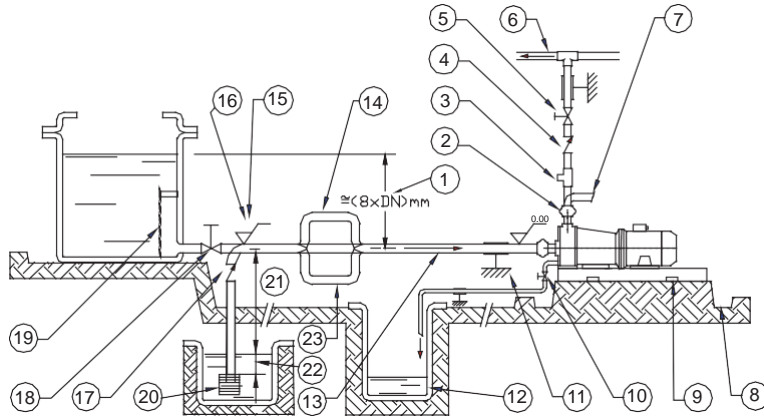

- anchor the pump to an adequate base plate having a mass at least 5 times that of the pump
- do not use anti-vibration mounts to fix the pump
- anti-vibration joints are recommended on the pipe connections
- manually verify that all rotating parts are free to turn without abnormal friction by turning the motor cooling fan
- make sure that the power supply is compatible with the data shown on the pump motor identification plate
- connect the motor to the power supply via a magnetic/thermal control switch
- ensure that star-delta starting is implemented for motors whose power is more than 15kW
- install emergency stop devices to switch off the pump in case of low liquid level (floating, magnetic, electronic, pressure-sensitive)
- ambient temperature as a function of the physical-chemical characteristics of the liquid to be pumped and in any case not greater or lower than the interval indicated in the GENERAL HINTS
- other environmental conditions in accordance with the IP protection of the motor
- install a drainage pit to collect any liquid overflow from the base drainage channel due to normal maintenance work
- leave enough free space around the pump for a person to move
- leave free space above the pump for lifting operations
- highlight the presence of aggressive liquids with coloured tags following the local safety regulations
- do not install the pump (made in thermoplastic material) in close proximity to heating apparatus
- do not install the pump in areas subject to solid or liquid matter falling
- do not install the pump in an explosive atmosphere unless the motor and its coupling have been adequately pre-arranged
- do not install the pump in close proximity to workplaces or crowded areas
- install extra protection guards for the pump or persons as the need arises
- install a spare equivalent pump in parallel

## START-UP

- verify that the instructions outlined in the INSTALLATION have been followed
- verify that fixing elements (screws and bolts) are closed
- verify the correct direction of rotation (clockwise from the motor side) supplying the motor with short impulses
- ensure that the NPSH available is greater than that required by the pump (in particular for hot liquids, liquids with high vapour pressure, very long suction pipes or negative suction lift)
- close the drain valve (pos. 19); totally flood the suction pipe and the pump
- start the pump with the suction valve completely open and the discharge valve partially closed
- slowly regulate the flow by opening or closing the discharge valve (never the suction valve). Make sure that the power absorbed by the motor does not exceed the rated one indicated on the motor identification plate
- do not operate the pump at the limit values of its performance curve: maximum head (discharge valve excessively closed) or maximum capacity (total absence of drops and geodetic head on the discharge side)
- set the operating point to that for which the pump was requested
- ensure that there are no abnormal vibrations or noise due to inadequate mounting or cavitation
- avoid short and/or frequent starts by properly setting the control devices

Motor power kW;	0,75÷5,5	7,5÷30	37÷110	132÷200	250÷315
Max. no. starts/hour 2 - 4 poli;	20 - 40	10 - 20	6 - 12	2 - 4	1 - 2

- ensure that the temperature, pressure and liquid characteristics are as those specified at the time of order.
- Warning!!! At the start-up be sure that all the internal hydraulic parts are not in CCW rotation (the cooling fan of the motor must stand or CW rotate), to prevent decoupling among magnetic driven parts of the pump; if the CCW rotation is due to the feed-back of the liquid in the discharge side, add a no-return valve in the plant.

## USE

- switch automatic control on
- do not activate valves whilst the pump is in operation
- risks of dangerous water hammer effects in case of sudden or improper valve actuation (only trained personnel should operate valves)
- completely empty and wash the pump before using a different liquid
- isolate or empty the pump if the crystallization temperature of the liquid is the same or lower than the ambient temperature
- stop the pump if the liquid temperature exceeds the maximum allowed temperature indicated in the general notes; if the increase is of approximately 20%, check internal parts
- close the valves in case of leaks
- wash with water only if compatible from the chemical point of view. As alternative use an appropriate solvent that will not generate dangerous exothermal reactions
- contact the liquid supplier for information on the appropriate fire precautions
- empty the pump in case of long periods of inactivity (in particular with liquids which would easily crystallize)

## SHUTDOWN

- disconnect the motor
- before starting maintenance, turn off the suction and discharge valves

## MAINTENANCE

- all these maintenance operations must be performed under the supervision of qualified personnel
- make periodic inspections (2 to 6 months depending on the type of liquid and the operating conditions) on the rotating parts of the pump; clean or replace as necessary
- make periodic inspections (3 to 5 months depending on the type of liquid and the operating conditions) on the functionality of the motor control system; efficiency must be guaranteed
- make periodic inspections (2 to 30 days depending on the type of liquid and the operating conditions) of the in-line and foot filters as well as of the bottom valve
- the presence of liquid below the pump could be a clue to pump problems
- excessive current consumption could be an indication of impeller problems
- unusual vibrations could be due to unbalanced impeller (due to damage or presence of foreign material obstructing its blades)
- reduced pump performance could be due to an obstruction of the impeller or damages to the motor
- motor damages could be due to abnormal friction within the pump
- damaged parts must be replaced with new original parts
- the replacement of damaged parts must be carried out in a clean dry area

## DISMANTLING

Tools required: size 10-13 socket spanner, screw driver (Phillips drive type), punch  $\varnothing < 4\text{mm}$ .

Bolts have right-hand thread

- all these maintenance operations must be performed under supervision of qualified personnel
- cut off the power supply from the motor and disconnect the electrical wiring; pull the wires out from the terminal box and isolate their extremities accordingly
- close the suction and discharge valves and open the drain valve
- use gloves, safety glasses and acid-proof overalls when disconnecting and washing the pump
- disconnect the piping and leave enough time for the residual liquid to exit the pump body and atmospheric air to fill the empty volume
- wash the pump before carrying out any maintenance work
- do not scatter the liquid in the environment
- before attempting to dismantle the pump ensure that its motor is disconnected and that it may not be started accidentally
- before the inspection, check that you have spare O-rings ready to hand for re-installing at the end of operations
- warning: operations near the magnet attract the tools. Proceed with cau-

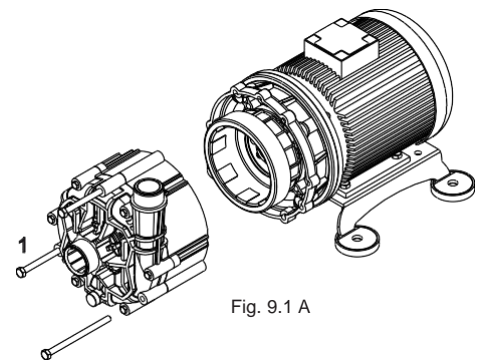

Fig. 9.1 A

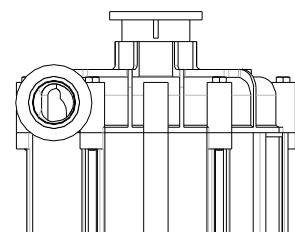

Fig. 9.1 B

tion to avoid damage.

- As described on paragraph no. 2 “Disassembling sequence”, unscrew the connections (POS.1) and remove the HYDRAULIC PARTS from the MOTOR PARTS
- Proceed separately to disassembly the HYDRAULIC PARTS or the MOTOR PARTS following the sequence described on paragraph no. 2 “Disassembling sequence ”.
- warning! The disassembly operations of parts magnetically connected involve great opposed forces: keep the MOTOR PARTS fixed on floor during the removing of the HYDRAULIC PARTS.
- to facilitate the disassembly operations keep the pump in vertical position (suction on top) Fig. 9.1 B
- warning! During the disassembly of the hydraulic parts do not bump the guide components
- warning! After the dismantling of the pump casing extract together the impeller and the central disc; extract avoiding radial movements Fig. 9.1 C
- disassembly the MOTOR PARTS: unscrew the 4 Phillips drive screws inside the drive magnet assembly, POS. E in Fig. 9.1 D
- warning! During the use of screw driver inside the drive magnet assembly you must oppose the magnetic attraction
- warning! After unscrewing the 4 screw (POS. E in Fig. 9.1 D) insert the punch  $\varnothing < 4\text{mm}$  in one of two extraction holes (POS. D in Fig. 9.1 D) to remove the collar (POS.C in Fig. 9.1 E) from the back and to allow the removing of the drive magnet assembly, sockets and collar (POS.A, POS.B, POS.C in Fig. 9.1 E) from the motor shaft.

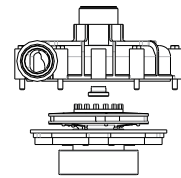

Fig. 9.1 C

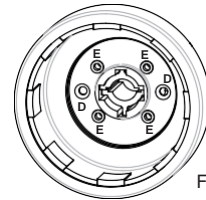
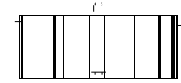

Fig. 9.1 D

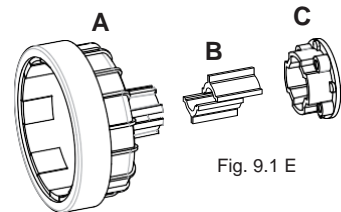

Fig. 9.1 E

## INSPECTION

Check:

- the pump shaft for cracks and excessive wear
- guide bushing for excessive wear (@ 5 %)
- counterthrust bushing for cracks or excessive wear
- pump shaft clutch
- that the guide bushing cooling circuit is not blocked
- the impeller, volute and rear chamber for abrasion and corrosion
- that the pressure balancing holes on the impeller blades are not blocked
- for lumps and clusters created by the pumped liquid (especially at the bottom the rear chamber)
- for infiltration of liquid into the chamber containing the inner magnets
- abrasions on the outside surface of the reinforcement chamber due to scratching of the outer magnets

Replace broken, cracked or deformed parts.

Reopen all the blocked pipes and eliminate any chemical agglomeration.

Clean all the surfaces before re-assembly, especially the O-ring seats (risk of drip leaks).

## ASSEMBLY

Tools required: size 10-13 socket spanner, screw driver (Phillips drive type)

Bolts have right-hand thread

Bolt torque setting:

	M4	M6	M8	M10	M12
(reduce by 25% on plastic parts)	Nm 4	14	24	25	40

(reduce by 25% on plastic parts) Nm 4 14 24 25 40

- all these maintenance operations must be performed under supervision of qualified personnel
- before the inspection, check that you have spare o-ring ready to hand for re-installing at the end of operations
- Proceed separately to disassembly the HYDRAULIC PARTS or the MOTOR PARTS following the backward sequence described on paragraph no. 2 “ Disassembling sequence ”.
- warning! Assemble the hydraulic parts to the motor parts only after the complete assembling of these two sub-assembly groups
- assembling the hydraulics and the motor parts, oppose the magnetical force keeping the hydraulic parts by the inlet and the outlet connectors
- warning! Locate the strainer on the motor flange as shown in Fig. 9.3 A
- the right location of the strainer allow the assembly of the hydraulic parts as shown in Fig. 9.3 B.
- if necessary insert sockets (POS.B) in the back of the drive magnet assembly (POS.A) Fig. 9.3 C
- the relative position of drive magnet assembly and sockets is shown in Fig. 9.3 C (a and b planes)
- insert the collar (POS. C) on the back of the drive magnet assembly keeping the side pump collar surface far as possible from the plane e
- verify that the collar surface with visible brass inserts is motor side
- remove possible traces of grease from motor shaft
- insert the assembled group (drive magnet assembly, sockets, collar) on the motor shaft
- after assembling on motor shaft verify the right position of sockets POS.B in drive magnet assembly POS.A (referring to planes a and b shown in Fig. 9.3 C)
- screw the 4 Phillips drive screws repeating the sequence E1, E2 ,E3 ,E4 and applying a torque @ 6 N m
- at the end of the screwing operation the collar will be at about 3-4 mm from the e plane shown in Fig. 9.3 C)
- warning! during the HYDRAULIC PARTS assembling keep the parts in vertical position
- assembly central disc and impeller before insert them in the rear casing, POS.F in Fig. 9.3 E
- warning! There are magnetical attraction forces in action assembling the central disc and impeller: avoid bump opposing manual force
- avoid radial movements during assembling the sub-assembly central disc-impeller in the rear casing
- the pumps range ROUTE are provided of a bidirectional axially alignment system (patented system)
- warning! verify that the value of the dimension Q shown in Fig. 9.3 F is 3 mm

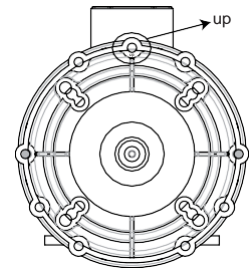

Fig. 9.3 A

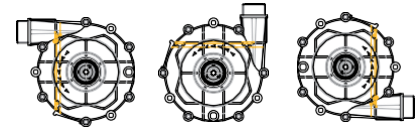

Fig. 9.3 B

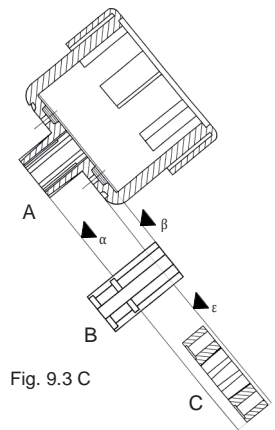

Fig. 9.3 C

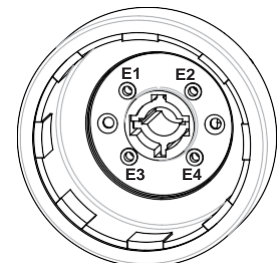

Fig. 9.3 D

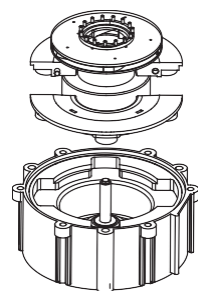

Fig. 9.3 E

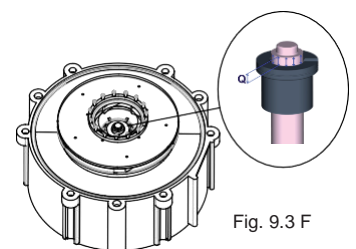

Fig. 9.3 F



## SAFETY RISKS

**WARNING! MAGNETIC FIELDS.** Magnetic pumps contain some of the most powerful magnets in existence. The magnets are positioned on the back of the impeller and the outer magnet housing. The magnetic fields may adversely affect persons fitted with electronic devices (e.g. pacemakers and defibrillators): such persons must not be allowed to handle magnetic pumps and magnetic pump components.



**WARNING! MAGNETIC FORCE.** Exercise extreme caution and follow instructions carefully during pump assembly/dismantling. Magnetic force attract (cause insertion of) internal and magnetic units, and are therefore a potential source of injury to fingers and hands.



**WARNING! CHEMICAL HAZARD.** The pumps are designed to pump different types of liquid and chemical. Follow the specific instructions to decontaminate during inspection or maintenance. §

**WARNING!** Safety risks for personnel mainly arise from improper use or accidental damages.

These risks may be of an electrical nature as far as the non-synchronous motor is concerned and may cause injury to hands if working on an open pump. Risks may also arise due to the nature of the liquids pumped. It is therefore of utmost importance to closely follow all the instructions contained in this manual so as to eliminate the causes that may lead to pump failure and the consequent leakage of liquid dangerous for both personnel and the environment.



Risks may also arise from improper maintenance or dismantling practices.

In any case five general rules are important:

- A - all services must be carried out by specialised personnel or supervised by qualified personnel depending on the type of maintenance required
- B - install protection guards against eventual liquid sprays (when the pump is not installed in remote areas) due to an accidental pipe rupture. Arrange for safety basins to collect possible leakage
- C - when working on the pump always wear acid-proof protective clothing
- D - arrange for proper conditions for suction and discharge valve closing during disassembly
- E - make sure that the motor is completely disconnected during disassembly.

Proper design and building of the plants, with well positioned and well marked piping fitted with shut-off valves, adequate passages and work areas for maintenance and inspections are extremely important (since the pressure developed by the pump could give some kind of damage to the plant in case this one should be faulty made or wear and tear-damaged).

It must be stressed that the major cause of pump failures leading to a consequent need to intervene is due to the pump running dry in manually operated plants. This is generally due to:

- the suction valve being open at start-up or
- the suction tank being emptied without stopping

## INSTALLATION AND START-UP PERSONNEL

Interventions allowed only to specialised personnel who may eventually delegate to others some operations depending on specific evaluations (technical capability required: specialisation in industrial plumbing or electric systems as needed).

## MAINTENANCE AND OPERATIONAL PERSONNEL

Interventions allowed to general operators (after training on the correct use of the plant):

- pump starting and stopping
- opening and closing of valves with the pump at rest
- emptying and washing of the pump body via special valves and piping
- cleaning of filtering elements

Interventions allowed to qualified personnel (technical capacities required: general knowledge of the mechanical, electrical and chemical features of the plant being fed by the pump and of the pump itself):

- verification of environmental conditions
- verification of the condition of the liquid being pumped
- inspections of the control/stop devices of the pump
- inspections of the rotating parts of the pump
- trouble shooting

## PERSONNEL RESPONSIBLE FOR REPAIRS

Interventions allowed to general operators under the supervision of qualified personnel:

- stopping of the pump
- closing of the valve
- emptying of pump body
- disconnection of piping from fittings
- removal of anchoring bolts
- washing with water or suitable solvent as needed
- transport (after removal of electrical connections by qualified personnel)

Interventions by qualified personnel (technical capacities required: general knowledge of machining operations, awareness of possible damage to parts due to abrasion or shocks during handling, know-how of required bolt and screw tightening required on different materials such as plastics and metals, use of precision measuring instruments):

- opening and closing of the pump body
- removal and replacement of rotating parts

## WASTE DISPOSAL

Materials: separate plastic from metal parts. Dispose of by authorized companies.

## IMPROPER USE

The pump must not be used for purposes other than the transfer of liquids.

The pump cannot be used to generate isostatic or counter pressures.

The pump cannot be used to mix liquids generating an exothermal reaction

The pump must be installed horizontally on a firm base.

The pump must be installed on a suitable hydraulic plant with inlet and outlet connections to proper suction and discharge pipes.

The plant must be able to shut off the liquid flow independently from the pump.

Handling of aggressive liquids requires specific technical knowledge

## OPERATING FAULTS AND POSSIBLE CAUSES

Pump does not deliver:

1. rotates in wrong direction
2. suction pipe is excessively long and tortuous
3. insufficient geodetic pump head or excessive suction geodetic lift
4. air infiltration into the suction pipe or branches
5. pump or suction pipe not completely covered by liquid
6. impeller channels blocked by impurities
7. check valve on discharge pipe jammed
8. geodetic system height is greater than maximum potential pump head
9. impeller jammed by considerable layer of crystals or by melting of materials for dry rotation.
10. bottom valve blocked by mud or other debris
11. bottom valve insufficiently immersed
12. bottom valve faulty, thereby causing suction valve to empty when pump stops
13. magnets release a much greater specific weight and flow rate of liquid than planned
14. the magnets release due start-up made while impeller is CCW moving (feed-back of the liquid in the discharge side)

Pump discharge rate or pressure insufficient:

see 01, 02, 03, 04, 05, 06, 10, 11, 12, 13

15. system's resisting head is greater than expected
16. suction pipe, closing valve and other items have an insufficient nominal diameter
17. small geometric pump suction head
18. damaged or worn impeller
19. liquid viscosity greater than expected
20. excessive quantities of air or gas in liquid
21. elbow joints, check valves or other items on the outlet port
22. liquid (especially if hot) with tendency to change into gaseous state

Pump absorbs too much power:

see 19

23. pump operates at greater capacity than expected
24. specific weight of liquid is greater than expected
25. impurities inside pump create abnormal wear
26. electric motor supply voltage is not rated voltage

Pump vibrates and is noisy:

see 25

27. operates at full capacity (no head)
28. pump or pipes inadequately fixed
29. eccentric impeller operation because of worn bushes

Pump's internal parts wear out too quickly:

see 25

30. liquid excessively abrasive
31. recurring cavitation problems (see. 02, 15, 19, 17)
32. high tendency of liquid to crystallise or polymerise when pump is not operating.
33. pump made of materials that are unsuitable for pumped liquid
34. operation with capacity too reduced



# TECHNICAL DATA

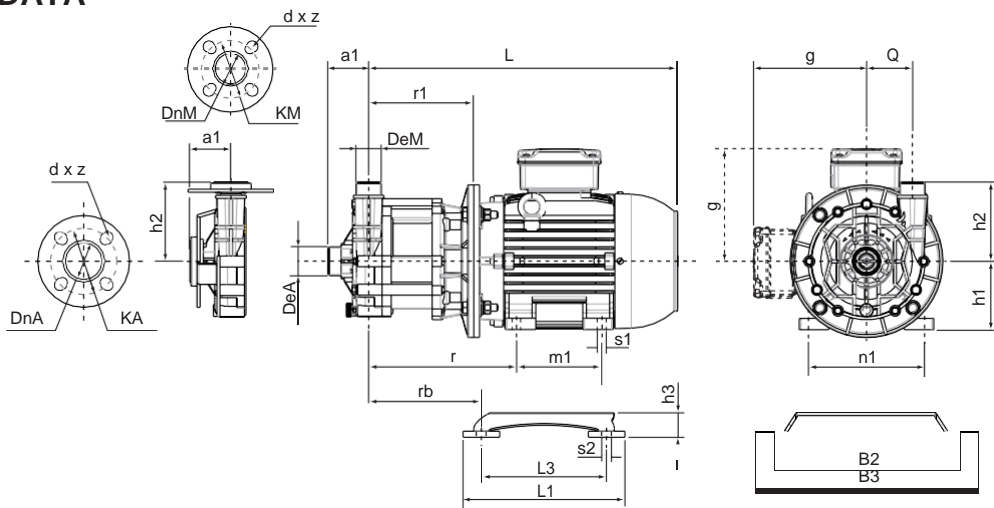

IEC - 50 Hz			model	IEC frame	DnA	DnM	DeA	DeM	KA iso / ansi / jis	KM iso / ansi / jis	d x z iso / ansi / jis	a1	L(°)	Q	h1	h2	r	r1	rb	m1	n1	s1	g(°)	L3	B2	S2	L1	B3	h3											
06.10	N	71	40 - 1" 1/2	32 - 1" 1/4	1" 1/2	1" 1/4	110 / 98 / 105	100 / 89 / 100	18 x 4 / 16 x 4 / 19 x 4	67	75	90	130	205	164	176	140	160	10	155	205	305	185	248	14	245	308	40												
	P	80A																											356	71	194	90	112	7	106					
	S	80B																											385	80	199	125	110							
10.10	N	80A																											385	80	199	125	110							
	P	80B																											405	90	205	149	161	100	140	142	185	248	245	308
	S	90S																											405	80	199	125	110							
10.15	N	80B																											405	80	199	125	110							
	P	90S																											405	90	205	149	161	100	140	142	185	248	245	308
	S	90L																											430	90	205	149	161	100	140	142	185	248	245	308
16.15	N	90S																											430	90	205	149	161	100	140	142	185	248	245	308
	P	90L																											430	90	205	149	161	100	140	142	185	248	245	308
	S	100																											478	100	227	164	176	140	160	10	155	205	305	259
16.20	N	90L	430	90	205	149	161	100	140	142	185	248	245	308																										
	P	100	478	100	227	164	176	140	160	10	155	205	305	259	359																									
	S																																							
02.30	N	90L	430	90	205	149	161	100	140	142	185	248	245	308																										
	P	100	478	100	227	164	176	140	160	10	155	205	305	259	359																									
	S																																							

IEC - 60 Hz			model	IEC frame	DnA	DnM	DeA	DeM	KA iso / ansi / jis	KM iso / ansi / jis	d x z iso / ansi / jis	a1	L(°)	Q	h1	h2	r	r1	rb	m1	n1	s1	g(°)	L3	B2	S2	L1	B3	h3												
07.11	N	80A	40 - 1" 1/2	32 - 1" 1/4	1" 1/2	1" 1/4	110 / 98 / 105	100 / 89 / 100	18 x 4 / 16 x 4 / 19 x 4	67	75	90	130	205	149	161	140	160	10	155	205	305	185	248	14	245	308	40													
	P	80B																											385	80	199	125	110								
	S	90S																											430	90	205	140	142								
07.14	N	80B																											385	80	199	125	110								
	P	90S																											405	90	205	149	161	100	140	142	185	248	245	308	
	S	90L																											405	80	199	125	110								
11.15	N	90S																											405	90	205	149	161	100	140	142	185	248	245	308	
	P	90L																											430	90	205	149	161	100	140	142	185	248	245	308	
	S	100																											478	100	227	164	176	140	160	10	155	205	305	259	359
11.23	N	90L																											430	90	205	149	161	100	140	142	185	248	245	308	
	P	100																											478	100	227	164	176	140	160	10	155	205	305	259	359
	S																																								
17.25	N	112	487	112	234	164	176	140	190	10	168	205	305	259	359																										
	P																																								
	S																																								
03.35	N	112	487	112	234	164	176	140	190	10	168	205	305	259	359																										
	P																																								
	S																																								

(1) can change for motors of different brands

dimension in mm

model			NEMA frame	DnA	DnM	DeA	DeM	KA (mm) iso / ansi / jis	KM (mm) iso / ansi / jis	d x z (mm) iso / ansi / jis	a1	L(°)	Q	h1	h2	r	r1	rb	m1	n1	s1	g(°)	L3	B2	S2	L1	B3	h3																																
NEMA - 60 Hz	07.11	N	56	40 - 1" 1/2	32 - 1" 1/4	1" 1/2	1" 1/4	110 / 98 / 105	100 / 89 / 100	18 x 4 / 16 x 4 / 19 x 4	2.65	2.94	4.5	5.125																																														
		P	56																										14.94	8.44	3	4.875	5.44																											
		S	145																										16.94	3.5	5	0.375	7.28	9.75	9.66	12.13																								
	07.14	N	143																										15.94	8.125	5.875	6.34	4	5.5																										
		P	145																										16.94	4	5	7	8.06	12																										
		S	182																										18.5	4.5	9.375	6.625	7.125	4.5	7.5	0.41	7	8.06	12																					
	11.15	N	145																										16.94	8.125	5.875	6.34	5	5.5	0.375	5.9	7.28	9.75																						
		P	182																										18.5	4.5	9.375	6.625	7.125	4.5	7.5	0.41	7	8.06	12																					
		S	184																										19.5	4.5	9.625	6.625	7.125	5.5	7.5	0.41	7	8.06	12	0.56																				
	11.23	N	182																										18.5	4.5	9.375	6.625	7.125	4.5	7.5	0.41	7	8.06	12																					
		P	184																										19.5	4.5	9.625	6.625	7.125	5.5	7.5	0.41	7	8.06	12																					
		S																																																										
	17.25	N	184																										19.5	4.5	9.625	6.625	7.125	5.5	7.5	0.41	7	8.06	12																					
		P																																																										
		S																																																										
	03.35	N	184																										19.5	4.5	9.625	6.625	7.125	5.5	7.5	0.41	7	8.06	12																					
		P																																																										
		S																																																										

IEC 50 Hz 2900 rpm	Model		06.10			10.10			10.15			16.15			16.20			02.30		
	Version		N	P	S	N	P	S	N	P	S	N	P	S	N	P	S	N	P	S
	WR	GF	WR	GF	WR	GF	WR	GF	WR	GF	WR	GF	WR	GF	WR	GF	WR	GF	WR	GF
Weigh pump	no motor	Kg	3	4	3	4	3	4	3	4	3	4	3	4	3	4	3	4	3	4
	+ IEC 3 fasi (°)	Kg	10	11	11	12	13	13	14	14	16	17	17	20	21	21	25	26	26	26
Max. head	m.c.l	11			14.5			18			23.5			26.5			31			
Max. capacity	m³/h	17			19			25			26			30			8			
Max. NPSH req..	m.c.l																			
Noise	dB	65			70			70			70			70			70			
Loads (ports-section)	Kg	Max. single strength value F(x,y,z) = 2,5																		
Motor	Frame		71	80A	80B	80A	80B	90S	80B	90S	90L	90S	90L	100L	90L	100L	/	90L	100L	/
	Power	kW	0.55	0.75	1.1	0.75	1.1	1.5	1.1	1.5	2.2	1.5	2.2	3	2.2	3	/	2.2	3	/
	Voltage	V	400 ± 5% 50 Hz																	
	Phase	n°	3 - 1 (< 3 kW)																	
	Protection	IP	55																	

IEC NEMA 60 Hz 3500 rpm	Model		07.11			07.14			11.15			11.23			17.25			03.35			
	Version		N	P	S	N	P	S	N	P	S	N	P	S	N	P	S	N	P	S	
	WR	GF	WR	GF	WR	GF	WR	GF	WR	GF	WR	GF	WR	GF	WR	GF	WR	GF	WR	GF	
Weigh pump	no motor	Kg	3	4	3	4	3	4	3	4	3	4	3	4	3	4	3	4	3	4	
	+ IEC 3 phase (°)	Kg	11	12	13	13	14	14	16	17	17	20	21	21	25	26	26	26	26	26	
	+ NEMA 3 ph. (°)	Lb	33	35	35	38	48	50	50	50	50	50	50	50	50	50	50	50	50	50	
Max. head	m.c.l	15.5			16.5			22			28			36			35				
Max. capacity	m³/h	15			19.5			24			27			30			10				
Max. NPSH req.	m.c.l																				
Noise	dB	70			70			70			70			74			74				
Loads (ports-section)	Kg	Max. single strength value F(x,y,z) = 2,5																			
Motor	IEC	Frame		80A	80B	90S	80B	90S	90L	90S	90L	100L	90L	100L		112			112		
		Power	kW	0.75	1.1	1.5	1.1	1.5	2.2	1.5	2.2	3	2.2	3		4			4		
		Voltage	V	460 ± 5% 60 Hz																	
		Phase	n°	3 - 1 (< 3 kW)																	
		Protection	IP	55																	
	NEMA	Frame		56	56	145	143	145	182	145	182	184	182	184		184			184		
		Power	HP	1	1 1/2	2	1 1/2	2	3	2	3	5	3	5		5			5		
		Voltage	V	460 ± 5% 60 Hz																	
		Phase	n°	3																	
		Protection	IP	55																	

(\*) can change for motors of different brands

## POSITIONING DRIVE MAGNET ASSEMBLY

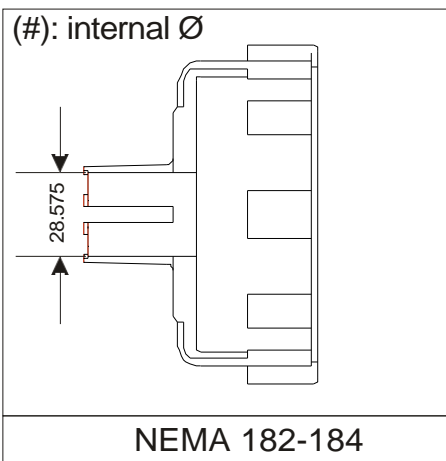
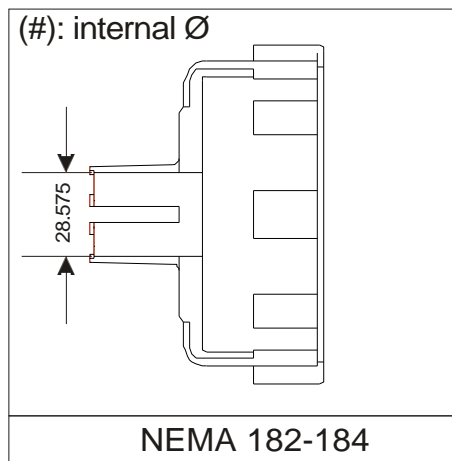
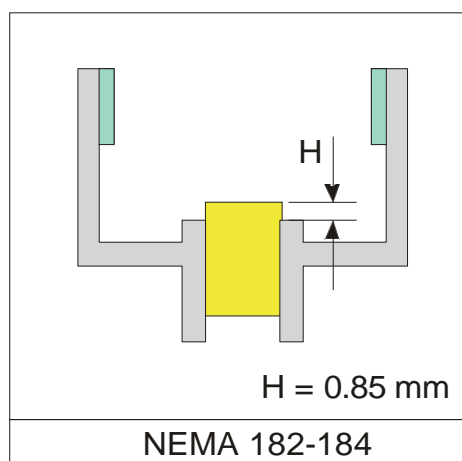
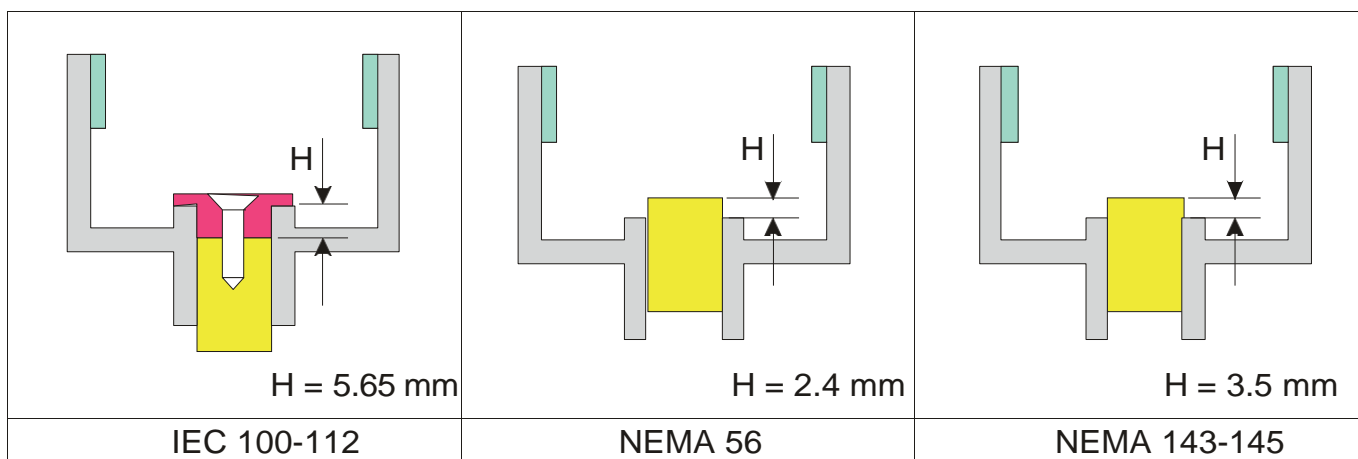
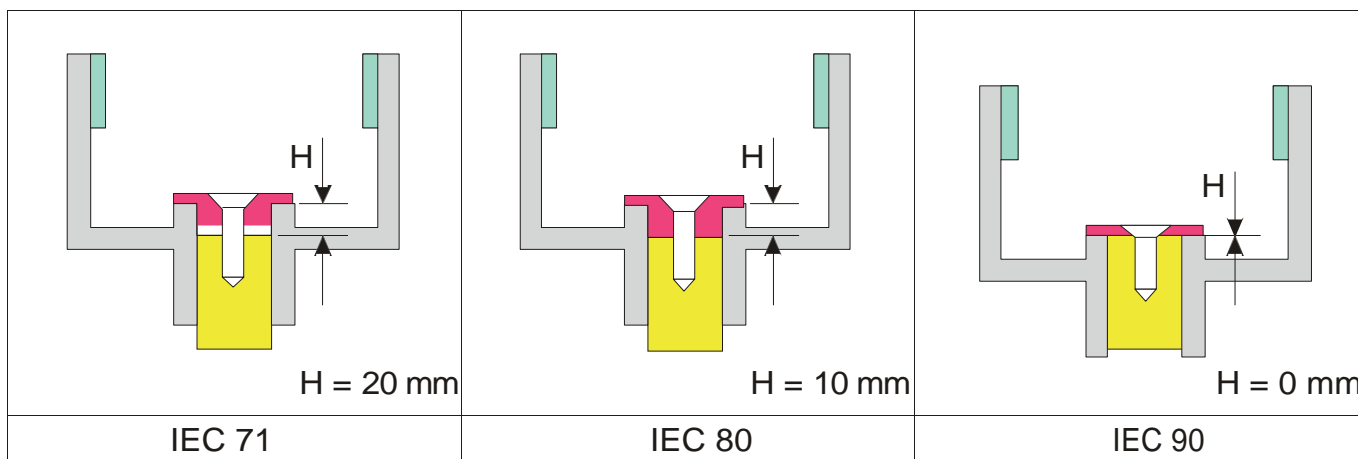

### CAUTIONS

- Verify that there are not damage to motor shaft, fan cap, motor feet, terminal box
- Verify that the nameplat data are correct
- Verify that shaft is perfectly clean from grease or dust, unlike use alcohol to degrease shaft.

## **GENERAL CONDITIONS OF SALE**

### **1. COMPLAINTS**

Complaints of any type must be made upon receiving the goods and within **one week** of discovering the defect. Complaints about incomplete orders or deterioration during transit must be made to us **immediately** and all the proofs of the irregularity must be collected in order to substantiate any claims against the carrier.

### **2. LONG TERM STORAGE – HORIZONTAL AND VERTICAL PUMPS**

The following storage procedure is recommended for pumps that will remain idle for extended periods prior to start-up (for accessory equipment such as motors and controls, refer to the appropriate equipment manufacturer for their recommended procedures).

1. Drain pump.
2. Cover suction and discharge flanges with flange protectors and plug all the auxiliary connections to exclude dust or dirt from pump internals.
3. Coat interior and exterior of all metallic items - in contact with the external atmosphere (unpainted) - with a rust preventative.
4. Remove breather and oiler and plug tapped holes in pump power frame.
5. Cover and wrap pump with barrier film sacks (suitable for a long-term preservation of materials that need a constant environment to maintain their properties). Protect with wooden box if storage area could result in damage to pump. Indoor storage is highly recommended.
6. Rotate shaft several times at 4-6 month intervals.

### **3. LONG TERM STORAGE PACKAGE**

Due to their unique corrosion resistant design, **ARGAL Centrifugal Pumps** require very little special preparation for long term storage (more than **four** months). Those customers who find it necessary to store centrifugal pumps for long periods of time may purchase a special Long Term Storage Package at: a nominal price. This package includes items 1, 2, 3, 4, and 5 as stated above using our standard wooden box. Cut away area on box will be noted for shaft rotation.

### **THIS LONG TERM STORAGE PACKAGE HAS A COST PER PUMP.**

### **4. WARRANTY**

Specifications, dimensions and any other information contained in our catalogues is to the best of our knowledge accurate. However, the above information is merely illustrative and is subject to modification without warning. In all cases we reserve the right to - at any moment - make any changes to our products that we deem to be appropriate and such changes shall not entitle the purchaser to make any claims against us. All drawings remain our exclusive property and may not be passed on to third parties or be reproduced without our written approval.

**DURATION OF WARRANTY:** Argal manufactures its products from first-class materials, uses qualified personnel and tests the different production stages. Within **twelve** months from the time of installation and no more than **eighteen** months from delivery Argal undertakes to examine any defective parts and to promptly replace any faulty parts free of charge if it is responsible for the fault. Such faults must not be due to wear, inexpert use or carelessness on the purchaser's part, fortuitous events or force majeure. The warranty period is shortened to **six** months if the machines work continuously twenty-four hours a day.

Even machines that are under warranty must be sent to Argal carriage paid. Once the machines have been repaired they will be returned to the purchaser carriage forward. The replaced parts remain the property of Argal and must be returned to Argal.

The warranty is voided: **1a)** if the machines have not been properly maintained; **1b)** if they have not been used in accordance with the technical standards set out in the manuals supplied with the delivery; **1c)** if the machines are dismantled without our prior authorisation; **1d)** if the machines are 'mistreated'; **1e)** if the machines are used to circulate liquids in applications that are different from those which have been specifically approved beforehand by ARGAL. We shall not be liable for the downtime arising from repairs to or the replacement of any machines of ours that are under warranty.

Argal shall not be responsible for any direct, accidental or indirect damage, injury or loss (including, but not limited to accidental or indirect damage arising from loss of profit or sales, or for any personal injury or damage arising or any other accidental or indirect loss) or for damage and injury caused by use of the machine or inability to use the machine. Before using the machine the user must check the suitability of the machine for its intended purpose and shall use the machine entirely at his own risk and responsibility.

The user notes that the pumps supplied to him by us oblige him, in accordance with Article 2050 of the Italian Civil Cod, to comply with all the legislative and regulatory standards governing dangerous activities such as using, storing and conveying aggressive and polluting chemical products.

The user also undertakes to comply with the prescriptions that apply to the system (such as guards, washers, seals etc) in which the pumps will be used and to comply with the installation instructions, checks and maintenance prescribed for pumps and installations. The user must also allow us, if necessary, to check the operating efficiency of the systems and to subsequently check that the pump has been correctly installed.

If the user fails to comply with the prescriptions laid down by us or prevents us from carrying out the above inspection, he voids all contractual warranty rights and warranty rights under the terms of Articles 1667 and 1668 of the Italian Civil Code.

**NOTE:** The purchase of the **ARGAL Long Term Storage Package** does not extend the standard pump warranty in any manner, i.e., **twelve** months from start-up not to exceed **eighteen** months from factory shipment. If an extension of our standard warranty is to be considered, the Long Term Storage Package must be furnished and the customer must agree to allow a ARGAL representative to inspect the equipment prior to installation and start-up. The customer shall bear the cost of this visit plus traveling expenses for the representative. As we have no control over the actual storage conditions, any repairs or repair parts required to put the equipment back in an "as new condition" shall be billed to the customer. If an extension of our standard warranty is required and if the customer is agreeable to the above conditions, contact ARGAL Division management, who has the sole authority to extend our standard warranty.

BS, 13.11.2017

**ARGAL S.r.l.**

Rev. 02 - 2017

## WARRANTY FORM

Company: _____	
Telephone: _____	Fax: _____
Address: _____	
Country: _____	Contact Name: _____
E-mail: _____	
Delivery Date: _____	Pump was installed (date): _____
Pump type: _____	Serial no.: _____
Description of the fault: _____	
_____	
_____	
<b>The installation</b>	
Liquid: _____	
Temperature (°C): _____	Viscosity (cPs): _____ Spec. grav. (Kg/m <sup>3</sup> ): _____ PH-value: _____
Contents of particles: _____ % of max size (mm): _____	
Flow (l/min): _____	Duty (h/day): _____ No. of starts per day: _____
Discharge head (mwc): _____	Suction head/lift (m): _____
<b>Other:</b> _____	
_____	
_____	
<b>Place for sketch of the installation</b>	



## MANUFACTURER DATA



### Production head and legal office:

Via Labirinto, 159 I - 25125 BRESCIA  
Tel: 030 3507011 Fax: 030 3507077

Administration:	Tel: 030 3507019
Sales Operation Manager:	Tel: 030 3507025
Customer service:	Tel: 030 3507023
Web:	www.argalpumps.com
E-mail:	sales.engineer@argal.it

Rev. 25 - 09/20

The INSTRUCTION MANUAL must be delivered to the pump-user , who takes diligent note of it, fills in data for Maintenance Department (page 1), keeps the file for subsequent reference. Possible modifications do not imply updating of the existing manuals

© Copyright 2020 - ARGAL srl  
Draw and text total or partial duplication is prohibited