

WOLTMANN PULSE EMITTER WATER METER

Data Sheet

FEATURES

- Dry dial
- Threaded Woltmann (2") type for cold and hot water
- Flange sizes range: from 2" to 8"
- Woltmann water meter for horizontal and vertical assembly
- Working temperature: cold water up to 60° C
CWCA mod. up to 130 °C @ 16 bar
- Epoxy coated cast iron housing (except for CWFI with brass housing)
- Max voltage 250 VAC, 200 VDC
- Max current 1.0 A
- Max power 10 VA
- Insulation voltage 4000 Vac
- Available water meter without pulse emitter

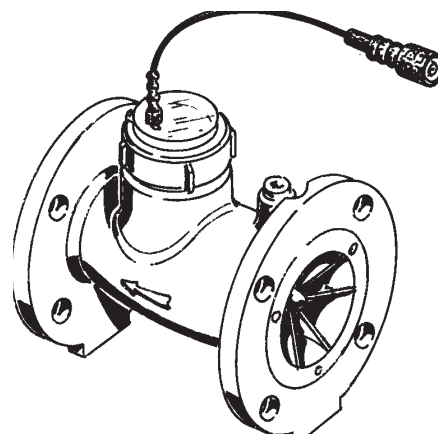

Configuration Info

MODELS		
CWFA.	"CWFA"	Woltmann cold water pulse emitter water meter
CWCA.	"CWCA"	Woltmann hot water pulse emitter water meter
CWFI.	"CWFI"	Woltmann cold water pulse emitter water meter (threaded 2")

Model CWCA. 015 0 01 L 0 2.5

GAUGES		
	inc	mm
050	2	50
065	2 1/2	65
080	3	80
100	4	100
150	6	150
200	8	200
250	10	250
300	12	300

CONNECTORS	
0	BNC
1	2 wires
3	2 wires (coaxial cable)

QUANTITY PER PULSES	
L	1 litre
D	10 litres
C	100 litres
M	1000 litres

PULSES PER LITRE

refer to the tables "Pulses per litre"

EMEC

ISO 9001:2008
ISO 14001:2004
OHSAS 18001:2007



Via Donatori di sangue, 1 - 02100 RIETI - Italy
Tel. +39 0746 2284 1 - Fax +39 0746 2284 2 - <http://www.emecpumps.com>

Documento soggetto a modifiche senza preavviso R2-09-18

WOLTMANN PULSE EMITTER WATER METER

Data Sheet

PULSES PER LITRE

PULSES PER LITER FOR CWFA / CWFI SERIES								
	Water meter caliber							
	50 - 2"	65 - 2,5"	80 - 3"	100 - 4"	150 - 6"	200 - 8"	250 - 10"	300 - 12"
Pulses for 10 lt	1-2-4	1-2-4	1-2-4	n/a	n/a	n/a	n/a	n/a
Pulses for 100 lt	1-2-4	1-2-4	1-2-4	1-2-4	1-2-4	n/a	n/a	n/a
Pulses for 1000 lt	1-2-4	1-2-4	1-2-4	1-2-4	1-2-4	1-2-4	1-2-4	1-2-4
Pulses for 10000 lt	n/a	n/a	n/a	1-2-4	1-2-4	1-2-4	1-2-4	1-2-4

PULSES PER LITER FOR CWCA						
	Water meter caliber					
	50 - 2"	65 - 2,5"	80 - 3"	100 - 4"	150 - 6"	200 - 8"
Pulses for 100 lt	1			n/a		
Pulses for 1000 lt	n/a			1		

DIMENSIONS

GAUGES	(mm)	50	65	80	100	150	200	250	300	CWFI 50
	(inch)	2	2 1/2	3	4	6	8	10	12	CWFI 2
L - Length (mm)		200	200	230	250	300	350	450	500	200
B - Width (mm)		165	185	200	200	283	340	406	460	-
H - Height (mm)		214	228	234	250	310	338	438	465	175
h - Height (mm)		70	84	90	106	130	158	258	330	-
Weight (kg)		12	13	15,5	19	35	47	75	95	5

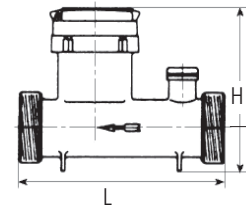
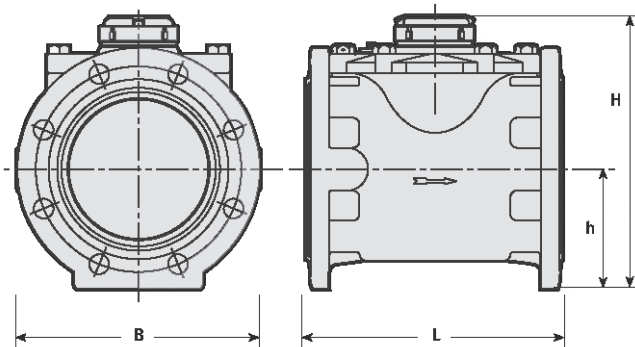

FEATURES

WSTsb		Maximum Flowrate (m³/h)	Nominal Flowrate (m³/h)	Transitional Flowrate (m³/h)	Minimum Flowrate (m³/h)	Flow (m³/h)	register capacity (m³)	Value	readable unit (liter)
Nominal size									
(mm)	(inch)								
50	2	78.75	63	1.01	0.63	0.15	10 ⁶	100	0.5
65	2 1/2	78.75	63	1.01	0.63	0.15	10 ⁶	100	0.5
80	3	125	100	1.6	1	0.25	10 ⁶	100	0.5
100	4	200	160	2.56	1.6	0.3	10 ⁷ /10 ⁶	100	5
150	6	312.5	250	4	2.5	0.8	10 ⁷ /10 ⁶	100	5
200	8	787.5	630	20.16	12.6	2	10 ⁸	50	50
250	10	1250	1000	32	20	3	10 ⁸	50	50
300	12	1250	1000	32	20	4	10 ⁸	50	50

Accuracy ±5%

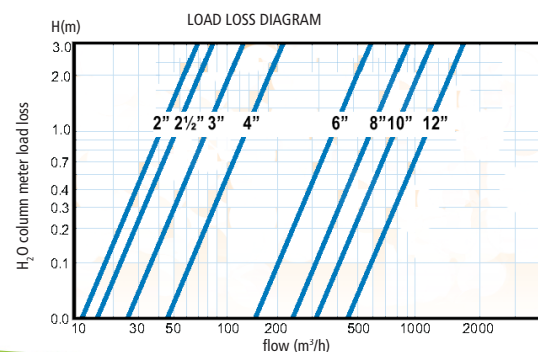
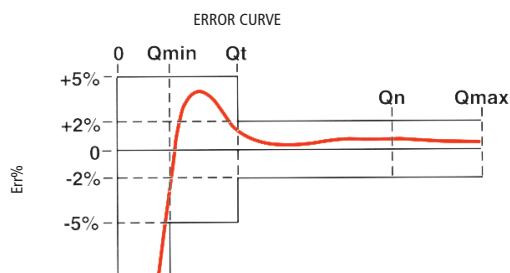

EMEC

ISO 9001:2008
ISO 14001:2004
OHSAS 18001:2007



Via Donatori di sangue, 1 - 02100 RIETI - Italy
Tel. +39 0746 2284 1 - Fax +39 0746 2284 2 - <http://www.emecpumps.com>

Documento soggetto a modifiche senza preavviso R2-09-18

WOLTMANN PULSE EMITTER WATER METER

Data Sheet

PN 16 Flat Flange
UNI EN 1092-1 (ex UNI 2278-67)

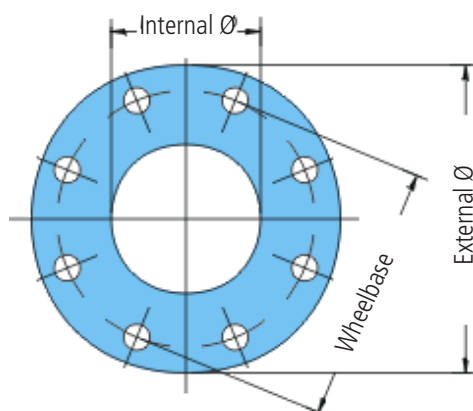

DN mm	External Ø mm	Internal Ø mm	Thickness mm	Hoses			Weight Kg
				Wheelbase mm	Diameter mm	Number	
15	95	22,0	14	65	14	4	0,50
20	105	27,5	16	75	14	4	1,00
25	115	34,5	16	85	14	4	1,00
32	140	43,5	18	100	18	4	2,00
40	150	49,5	18	110	18	4	2,00
50	165	61,5	19	125	18	4	2,50
65	185	77,5	20	145	18	8 *	3,00
80	200	90,5	20	160	18	8	3,50
100	220	116,0	22	180	18	8	4,50
125	250	141,5	22	210	18	8	5,50
150	285	170,5	24	240	22	8	7,00
200	340	221,5	26	295	22	12	9,50
250	405	276,5	29	355	26	12	14,0
300	460	327,5	32	410	26	12	19,0
350	520	359,0	35	470	26	16	28,0
400	580	411,0	38	525	30	16	36,0
450	640	462,0	42	585	30	20	46,0
500	715	513,5	46	650	33	20	64,0
600	840	616,5	52	770	36	20	96,0
700	910	-	-	840	36	24	-
800	1.025	-	-	950	39	24	-
900	1.125	-	-	1.050	39	28	-
1.000	1.255	-	-	1.170	42	28	-

* - In base alla EN 1092-2 (flange in ghisa) e al prEN 1092-3 (flange in lega di rame), le flange aventi questo DN e PN possono essere fornite con 4 fori. Se le flange di acciaio sono prescritte con 4 fori, esse possono essere fornite a seguito di accordo tra il fabbricante e il committente.

EMEC

ISO 9001:2008
ISO 14001:2004
OHSAS 18001:2007



Via Donatori di sangue, 1 - 02100 RIETI - Italy
Tel. +39 0746 2284 1 - Fax +39 0746 2284 2 - <http://www.emecpumps.com>

Documento soggetto a modifiche senza preavviso R2-09-18